

## Small intelligent tachometer/line speed meter T3ZX

Technical Manual

Version number: EN-V1-03



### About us

Guangzhou Tmcon Electronic Technology Co, Ltd.

Address: No.1, Xinhe Road West Street, Xier Village, Luopu Street, Panyu District, Guangzhou

Phone: +86 13533063770

WeChat : +86 13533063770

WhatsApp: +86 13533063770

Email: chinatmcon@163.com

Alternatively, click on the instant messaging tool on the [www.china-tmcon.com](http://www.china-tmcon.com) website to answer your questions online

Thank you very much for choosing TMCON products,  
In order to better use this product, please read the following before using.

## ■ Safety precautions

---

### Attention

Do not touch the terminals while power is on, otherwise minor injuries may occur due to electric shock.



Do not allow metal objects, conductors, debris (such as cuttings) from installation work, moisture, or other foreign matter to enter the digital controller, the setup tool ports, or between the pins on the connectors on the Setup Tool cable. Otherwise it may cause electric shock, short circuit or machine malfunction.



Do not use the product where subject to flammable or explosive gas. Otherwise, it may cause mild injury due to the explosion.



Never disassemble, modify, or repair the product or touch any of the internal parts. Otherwise, it may cause mild electric shock, fire, and equipment failure.



This equipment is an open processing controller. Do not use it in a control cabinet where fire may occur. When using more than 2 open-circuit switches, please turn off all switches before repair inspection, so that the product is in a power-off state.



## ■ Main features

---

- DIN 36×72mm standard size, arc-shaped“Sunglasses filter lens” panel display, bright visual experience.
- With powerful functions, it can display speed, line speed, pulse frequency, flow rate, etc., and can also have one alarm output.
- There are four alarm modes available for setting: upper and lower limits, range, upper and lower limits.
- The measurement range is wide, whether it is ultra-low speed or ultra-high speed, it can measure accurately.
- With functions such as automatic zeroing, smoothing processing, and starting compensation timing.
- The prescaling function (signal and display ratio) is 0.0001~99.9999 can convert the tachometer into line speed meter.
- The humanized operation interface design makes the parameter setting of single row display easy to operate.
- High performance switching power supply design ensures stable operation of microcomputers.
- Strong anti-interference performance, precise and reliable measurement.

## ■ Technical reference

Models	T3ZX-N	T3ZX-1P
Functional categories	Display dedicated type	With 1 alarm output type
External dimension (mm)	36(high)×72(wide)×66(depth)	
Hole size (mm)	31(high)×67(wide)	
Power supply	AC100~240V 50/60Hz or AC/DC12~24V (The default delivery is 100~240V, If you need 12~24V, please declare the voltage at the time of ordering)	
Permissible voltage range	85~110%	
Power consumption	About 5VA (AC240V) , about 3.2VA (DC24V)	
Display mode	Single row LED digital tube display	
Display range	0~999999 (6-digit)	
Counting speed	3	
Measuring range	30Hz: 0.0001Hz~30.00Hz, 10KHz: 0.0001Hz~10KHz	
Detect rotation range	0.06~600000rpm (1 pulse/rotation)	
Measurement accuracy	± 0.1% FS. ± 1 digit max (23 ± 5°C)	
Pulse metering method	Cycle measurement method	
Alarm mode	None	HI-LO, AREA, HI, LO
HI-LO, AREA, HI, LO	0.0001~99.9999	
Decimal point adjustment	0/0.0/0.00/0.000/0.0000(Selectable settings)	
Input signal	Counting signal, Hold signal	
Input method	No-voltage (NPN) input/voltage (PNP) input (Selectable settings) No-voltage inputs: ON impedance: 1KΩ max (Leakage current: 12mA at 0Ω) ON residual voltage: 3V max OFF impedance: 100KΩ min Voltage input: High (logic) level: 4.5 to 30VDC Low (logic) level: 0 to 2VDC (Input resistance: approx 4.7KΩ)	
Alarm output	None	1-way relay output, Contact capacity: 3A/AC250V resistive load
Auxiliary power output	12VDC ± 10% 100mA Max	
Insulation withstand voltage	AC2000V 50/60Hz 1min	
Usage environment	Temperature -10~+60°C (not freezing or exposed), humidity: 25~85% RH	

## ■ Dimensions (mm) and installation instructions

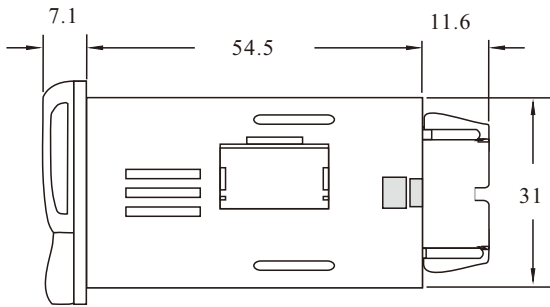
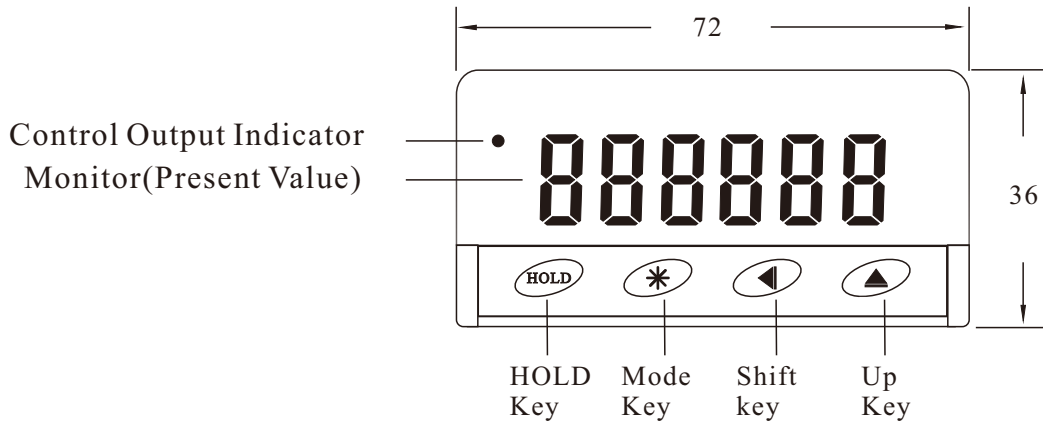

Panel Cutouts(mm) :

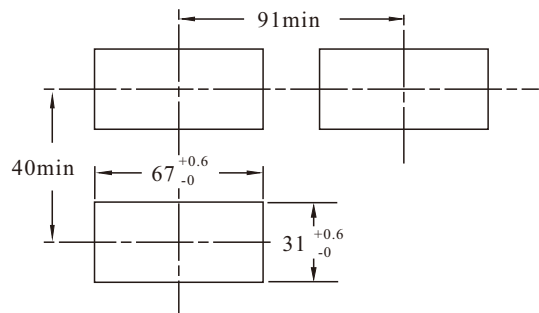

## ■ Comparison value set ( T3ZX-N doesn't have this set )

- T3ZX-1P Output Mode: HIHI or LOLO

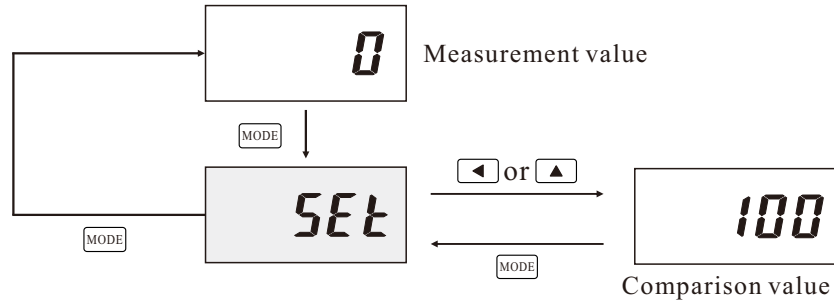

### Comparison Value

Set comparison value. The measurement value is compared to comparison value and output is made according to the selected output mode.

- T3ZX-1P Output Mode: HI-LO or AREA

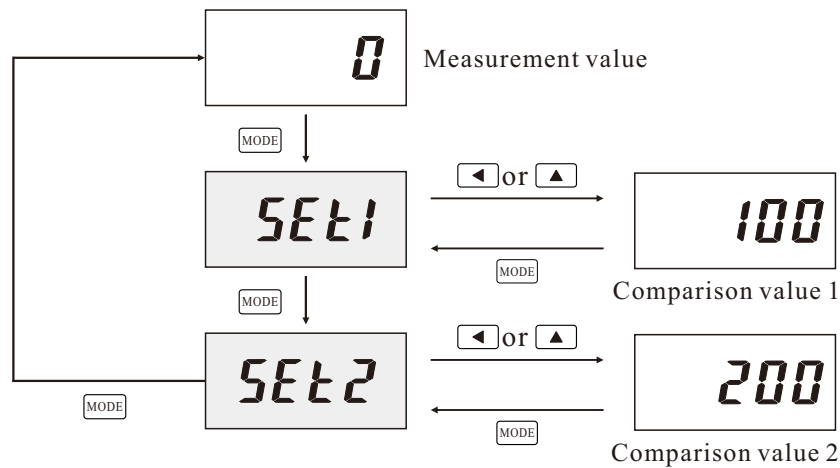

### Comparison Value 1/Comparison Value 2

Set comparison value 1 and comparison value 2. The measurement value is compared to comparison value 1 and comparison value 2 and output is made according to the selected output mode.

# Settings for Advanced Functions

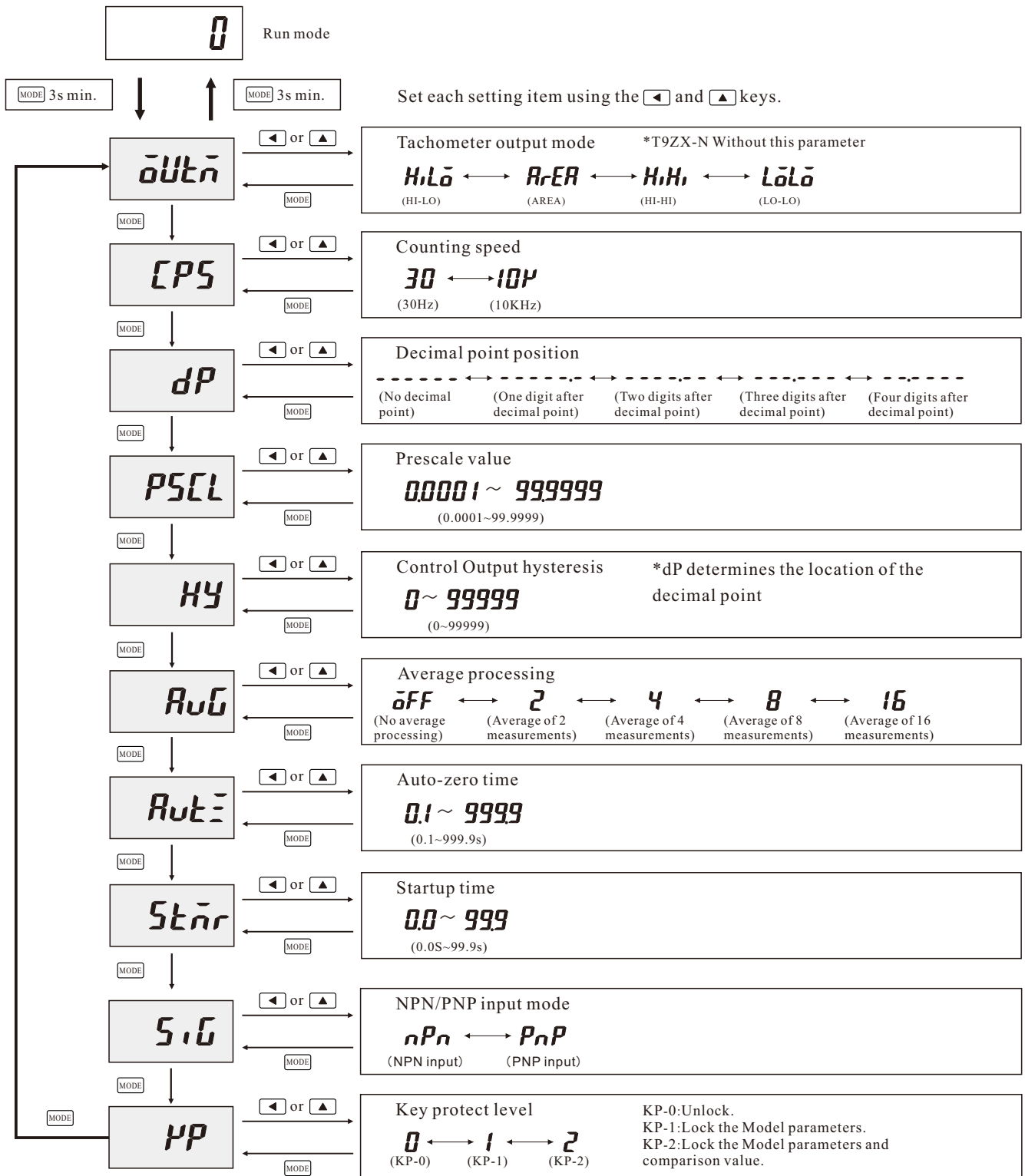

# ■ Explanation of Functions

● Counting Speed ( **CP5** )

Set the maximum counting speed (30 Hz/10 kHz) for CP1 input. If contacts are used for input signals, set the counting speed to 30 Hz. Processing to eliminate chattering is performed for this setting.

● Decimal Point Position ( **dP** )

Decide the decimal point position for the measurement value, OUT1 set value, and OUT2 set value.

● Prescale Value ( **P5LL** )

It is possible to display the rate of rotation or the speed of a device or machine to which the T3ZX is mounted by converting input pulses to a desired unit. If this prescaling function is not used, the input frequency(Hz) will be displayed.

The relationship between display and input is determined by the following equation. Set the prescale value according to the unit to be displayed.

$$\text{Displayed value} = f \times a$$

f: Input pulse frequency (number of pulses in 1 second)

a: Prescale value

1. Displaying Rotation Rate

Display unit	Prescale value (a)
rpm	1/NX60
rps	1/N

N: Number of pulses per revolution

Example: In order to display the rate of rotation for a machine that outputs 5 pulses per revolution in the form □□.□ rpm:

1. Set the decimal point position to 1 decimal place.
2. Using the formula, set the prescale value to  $1/N \times 60 = 60/5 = 12$ .

2. Displaying Speed

Display unit	Prescale value (a)
m/min	$\pi dX1/NX60$
m/s	$\pi dX1/N$

N: Number of pulses per revolution

d: Diameter of rotating body (m)

$\pi d$ : Circumference (m)

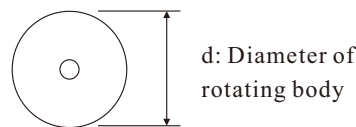

● Average Processing ( **Avg** )

Flickering display and output chattering can be prevented using average processing (simple averaging). Average processing can be set to one of four levels: no average processing, 2 times (i.e., the average of 2 measurement values) 4 times, or 8 times. The measurement cycle will be equal to the sampling cycle (200 ms) multiplied by the average processing setting (i.e., the number of times). Average processing enables fluctuating input signals to be displayed stably. Set the optimum number of times for the application.

● Auto-zero Time ( **AutZ** )

It is possible to set the T3ZX so that if there is no pulse for a certain time the display is force-set to 0. This time is called the auto-zero time. Note: Set the auto-zero time to a time slightly longer than the estimated interval between input pulses and within the setting range(0.1 to 999.9 s). It will not be possible to make accurate measurements if the auto-zero time is set to a time shorter than the input pulse cycle. Setting a time that is too long may also result in problems, such as a time-lag between rotation stopping and the alarm turning ON.

● Startup Time ( **Stnr** )

In order to prevent undesired output resulting from unstable input immediately after the power supply is turned ON, it is possible to prohibit measurement for a set time (0.0 to 99.9 s), the startup time. It can also be used to stop measurement and disable output until the rotating body reaches the normal rate of rotation, after the power supply to the T3ZX and rotating body are turned ON at the same time.



# ■ Output Mode Settings

● T3ZX-1P(A group of alarm output)

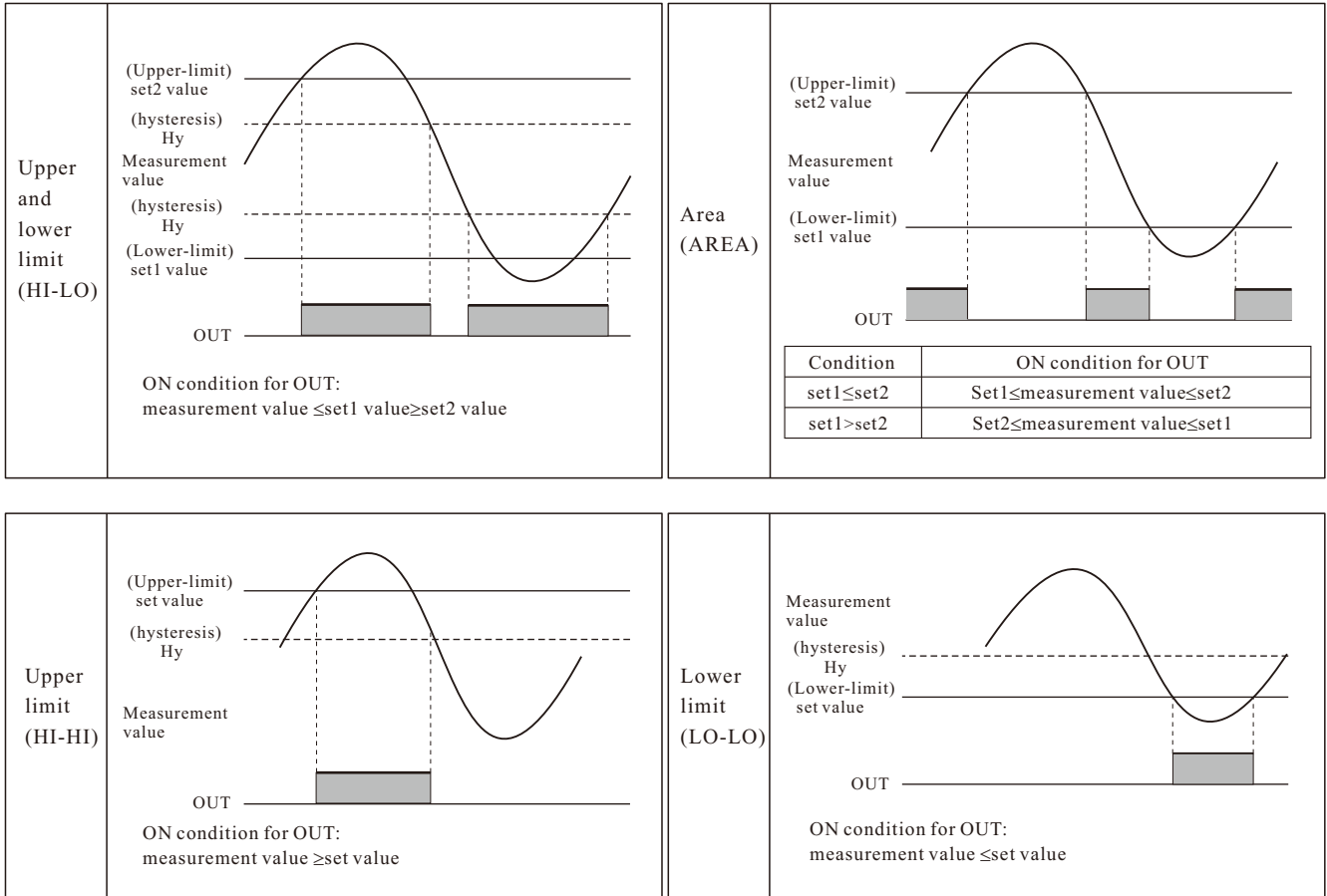

## ■ Wiring diagram

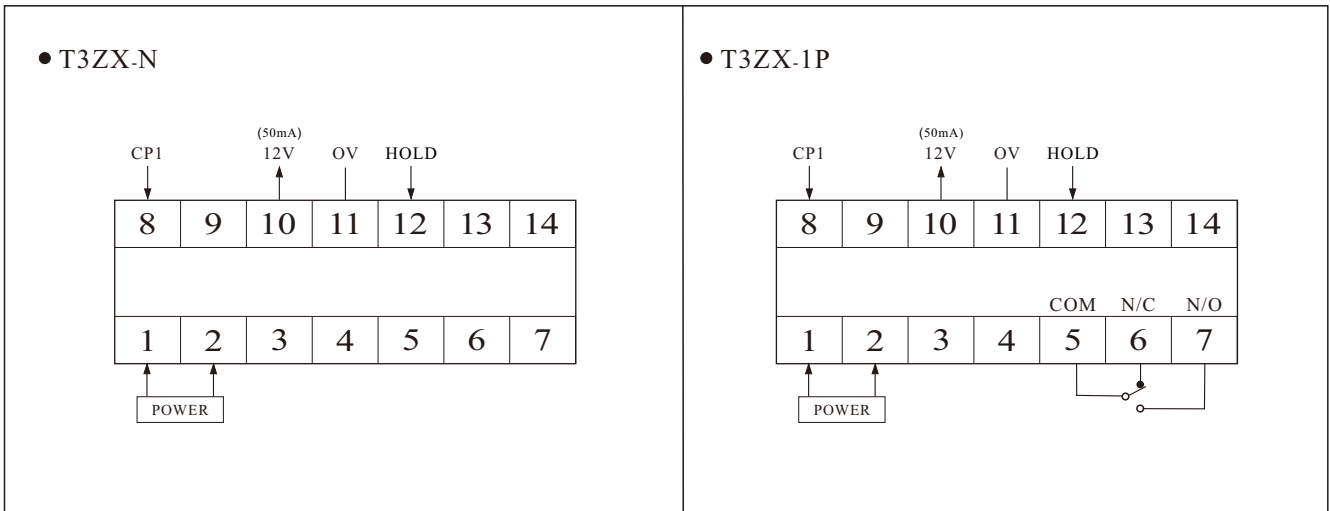

## ■ Signal input wiring method

