

Classic LED display Universal Economical Temperature Controller AiFUZZY-803

Technical Manual
Version number: EN-V8-01



Contact Us

Guangzhou Tmcon Electronic Technology Co, Ltd.

Address: No.1, Xinhe Road West Street, Xier Village, Luopu Street, Panyu District, Guangzhou

Phone: +86 13533063770

WeChat : +86 13533063770

WhatsApp: +86 13533063770

Email: info@tmcon.cn

Alternatively, click on the instant messaging tool on the www.china-tmcon.com website to answer your questions online

Thank you very much for choosing TMCON products,
In order to better use this product, please read the following before using.

■ Safety precautions

Attention

Do not touch the terminals while power is on, otherwise minor injuries may occur due to electric shock.



Do not allow metal objects, conductors, debris (such as cuttings) from installation work, moisture, or other foreign matter to enter the digital controller, the setup tool ports, or between the pins on the connectors on the Setup Tool cable. Otherwise it may cause electric shock, short circuit or machine malfunction.



Do not use the product where subject to flammable or explosive gas. Otherwise, it may cause mild injury due to the explosion.



Never disassemble, modify, or repair the product or touch any of the internal parts. Otherwise, it may cause mild electric shock, fire, and equipment failure.



This equipment is an open processing controller. Do not use it in a control cabinet where fire may occur. When using more than 2 open-circuit switches, please turn off all switches before repair inspection, so that the product is in a power-off state.



If the output relays are used past their life expectancy, contact fusing or burning may occasionally occur. Always consider the application conditions and use the output relays within their rated load and electrical life expectancy. The life expectancy of output relays varies considerably with the output load and switching conditions.



■ 1. Main features

- Adopting SMD LED light is combined into Nixie tube, and the LED light is directly SMT welded to the controller PCB motherboard (Old controller purchase Plug-in Nixie tube from LED Nixie tube manufacturer), which not only reduces the cost, but also autonomous controlling the quality of LED.
- The measurement accuracy is 0.25, and the resolution is further upgraded, and the measurement is more accurate and stable.
- AiFUZZY artificial intelligence adjustment algorithm perfectly combines fuzzy control and adaptive PID control, with AT self -setting and AT self -learning functions, It can automatically learn and remember some features of the controlled object during adjustment to optimize the effect. It has the control characteristics without overshoot and undershoot adjustment, and can also obtain excellent control effects on complex and difficult control objects.
- Support a variety of thermocouples and thermal resistance inputs. Setting through parameters can be freely switched.
- Support multiple output specifications: relay contact switch, SSR solid relay drive voltage, SCR no contact switch.
- With decimal point selection and degrees Celsius and Fahrenheit selection Settings.
- Further improving the anti -interference performance, so that it can also work stably in a worse electromagnetic interference environment.
- Using high -performance switching power supply design, strong load capacity, select of wide temperature range and high internal pressure components to adapt to various harsh environments, with lightning protection and surge.
- The power supply adopts a self-healing circuit design, which can automatically cut off power to protect the instrument in case of overvoltage or undervoltage. When the voltage is normal, it can automatically restore normal power supply.
- This model positioning: designed for mechanical equipment to provide a simple function, economic price, stable performance, accurate control temperature controller.

2. Technical Parameter

type	G - type panel	D - type panel	A - type panel	E - type panel	F - type panel
Panel size (wide × high)	48×48mm	72×72mm	96×96mm	48×96mm (Vice)	96×48mm (Horizontal)
Open -hole size (wide × high)	45×45mm	68×68mm	92×92mm	45×92mm	92×45mm
Installation method	Embedded panel installation				
Power supply	AC100~240V 50/60Hz; or DC12~24V				
Allow the range of voltage changes	85%~ 110%of the rated power voltage				
Power consumption	About 5VA when AC100 ~ 240V, and about 3.5VA at DC24V				
Display method	7 -segment LED digital display and separate indicators				
Input specifications and measurement range	Thermocouple: K (-50 ~+1300 ° C), E (0 ~ 800 ° C), J (0 ~ 1000 ° C), n (0 ~ 1300 ° C) Thermal resistance: PT100 (-200 ~+600 ° C)				
Decimal point	0 (none), 0.0 (1 digits)(set by DP parameters)				
measurement accuracy	Level 0.25				
The sampling period	Sample 10 times per second; set the digital filter parameter INF = 0, the response time ≤ 0.5 seconds				
control method	1.ON/OFF Position adjustment method (adjustable hysteresis) 2.AiFUZZY artificial intelligence adjustment, advanced control algorithm including fuzzy logic PID adjustment and parameter self-tuning function				
Control cycle	0.1 ~ 300.0 seconds adjustable				
Relay contact switch output	3A/20VAC or 3A/30VDC				
SSR voltage output	12VDC 50mA or 9VDC 50mA (for driving SSR solid -state relay)				
SCR non-contact output module	100~240VAC/0.2A (continuous); 2A (20mS momentary, 5S repetition period)				
Electromagnetic Compatibility	IEC61000-4-4 (electrical fast transient burst) ±6KV/5KHz, IEC61000-4-5 (surge) 6KV, and under the interference of 10V/m high-frequency electromagnetic field, the instrument does not crash, the I/O malfunctions will not emerge either, and the fluctuation of the measured value does not exceed ±5% of the range				
Isolation withstand voltage	The power supply side, the relay contact and the signal side are ≥ 2300VDC; the interdependent weak electricity signal end ≥ 600VDC				
Use environment	Temperature -10 ~+60°C (not freezing or exposed), humidity ≤90%RH				
Storage environment	Temperature -25 ~+70°C (not freezing or exposed), humidity ≤90%RH				

3. Model definition

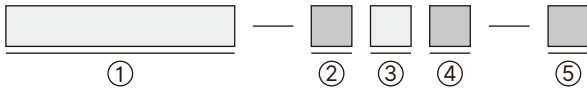

①	②	③	④	⑤
Model	Panel size	OUTP Control output	ALM Alarm output	Meter power supply
AiFUZZY803	G	N	N	N or not write
	D	R1	R1	D
	E	Q1	R2	
	F	W1	R3	
	A	W2	R4	
		Q7		

① Model

Code name	Explanation
AiFUZZY803	Classic LED display Universal Economical Temperature Controller

② Indicates the size of the meter

Code name	Explanation
G	Panel size 48 × 48mm (wide × high), open hole size 45 × 45mm
D	Panel size 72 × 72mm (wide × high), open hole size 68 × 68mm
E	Panel size 48 × 96mm (wide × high) (vertical), open hole size 45 × 92mm
F	Panel size 96 × 48mm (wide × high) (horizontal), open hole size 92 × 45mm
A	Panel size 96 × 96mm (wide × high), opening size 92 × 92mm

③ Indicates the installable module for OUTP control output

Code name	Explanation
N	No installed touch module
R1	Single circuit relay normally open contact switch output module, module capacity: 30VDC/3A, 250VAC/3A
Q1	SSR Solid-state relay drive voltage output module, 12VDC/50mA
W1	Normally open thyristor contactless output module, capacity: 100-240VAC/0.2A, with the characteristic of "not burnt out"
W2	Normally closed thyristor contactless output module, capacity: 100-240VAC/0.2A, with the characteristic of "not burnt out"
Q7	Built -in SSR solid -state relay, and interconnect in the instrument and the power supply of the instrument, directly output the power supply voltage module (for example, the power supply is connected to 220V, the output 220V voltage, the power supply is 110V, the output 110V voltage), suitable for 1.5A/220V small small small small Power load (customized)

④ Indicates the installable module for ALM alarm output

Code name	Explanation
N	No installed touch module
R1	One-way, AL1 alarm output (relay normally open contact switch output module), contact capacity: 30VDC/3A, 250VAC/3A
R2	Two-way, AL1+AL2 alarm output (relay normally open contact switch output module), contact capacity: 30VDC/3A, 250VAC/3A
R3	One-way, AL2 alarm output (relay normally open + normally closed contact switch output module), contact capacity: 30VDC/3A, 250VAC/3A
R4	Two-way, AL1 (relay normally open contact switch output module)+AL2 (relay normally open + normally closed contact switch output module) alarm output, contact capacity: 30VDC/3A, 250VAC/3A

⑤ Indicates the power supply power supply

Code name	Explanation
N or not write	100~240VAC power supply
D	12-24VDC power supply

■ 4. Wiring diagram

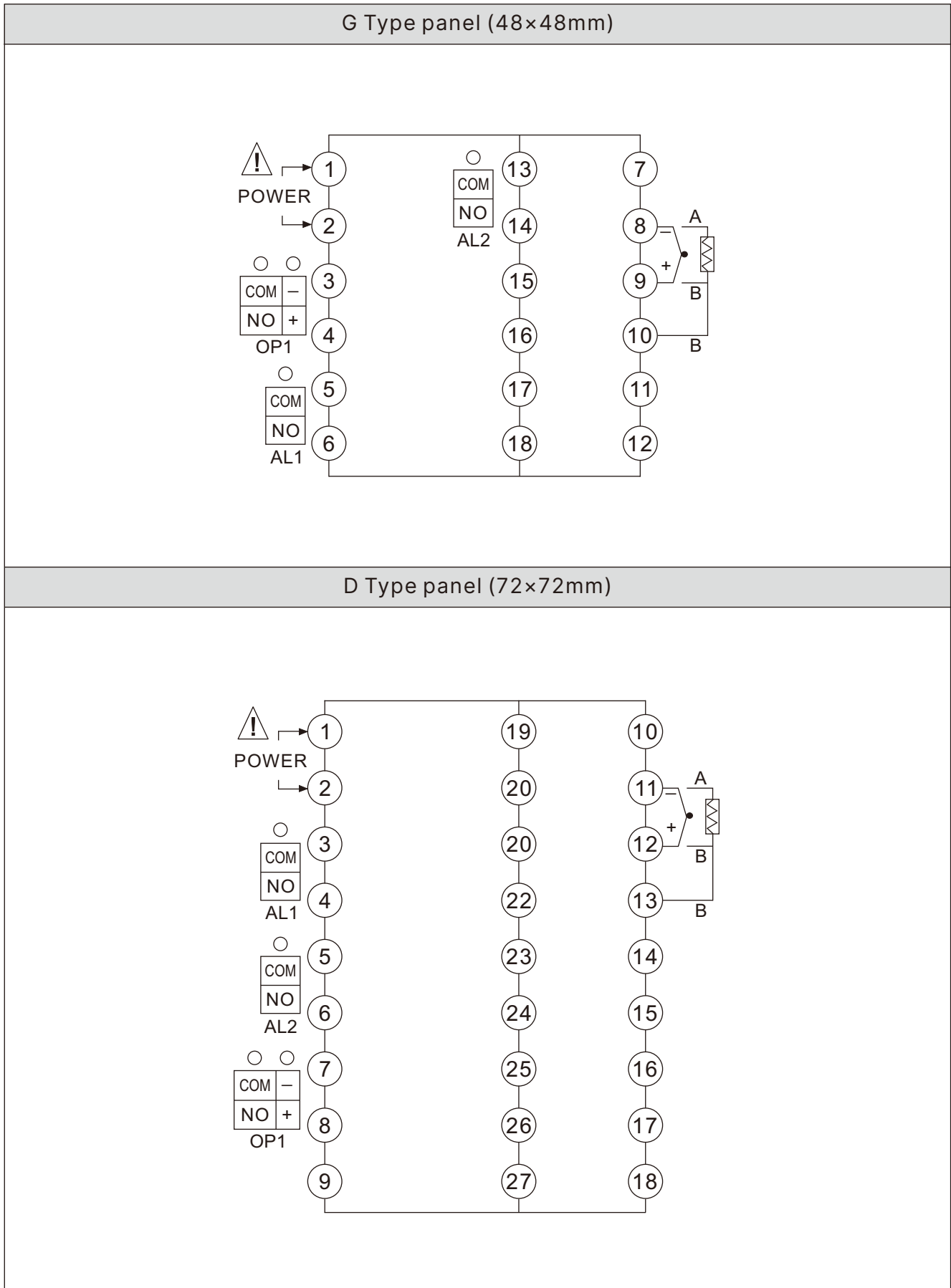

E,F,A Type panel (48×96mm/96×48mm/96×96mm)

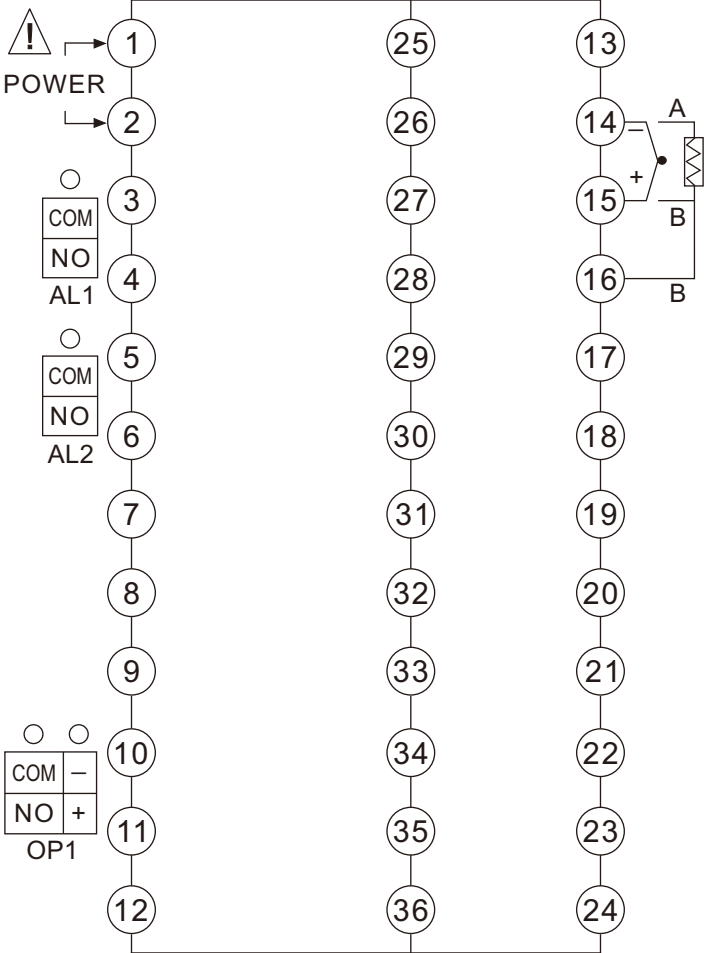

This wiring diagram visually conforms to the viewing of A and E type panels, while the F type panel is a horizontal panel,Visually, it is necessary to rotate 90 degrees counterclockwise according to this wiring diagram to view, and the terminal number remains unchanged.

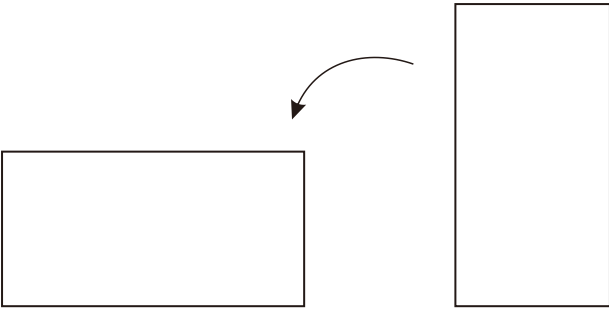

5. Panel description

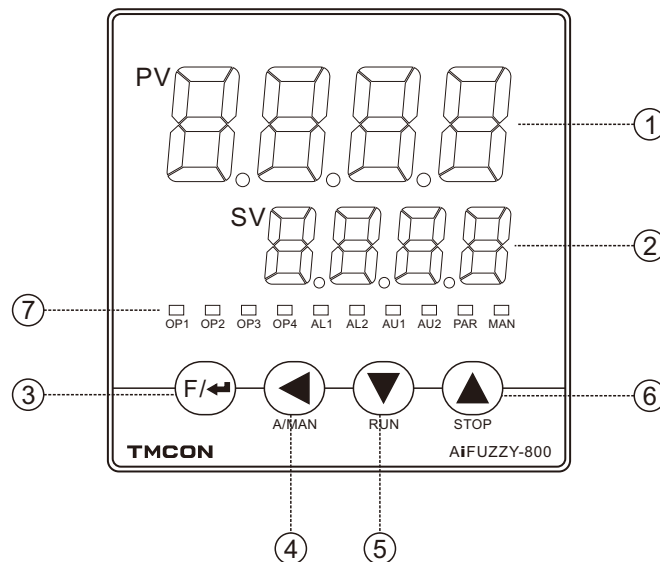

- ① First display window(upper display window) ,displays the measured value PV, parameter name, etc.
- ② Second display window(The lower display window) ,displays the given value SV, alarm code, parameter value, etc.
- ③ Set key, used to enter parameter setting status, confirm parameter modification, etc.
- ④ Data shift key .
- ⑤ Data decrease key.
- ⑥ Data increase key.
- ⑦ Output indicator lights, corresponding to module output action indicators.

6. Display status and operation flowchart

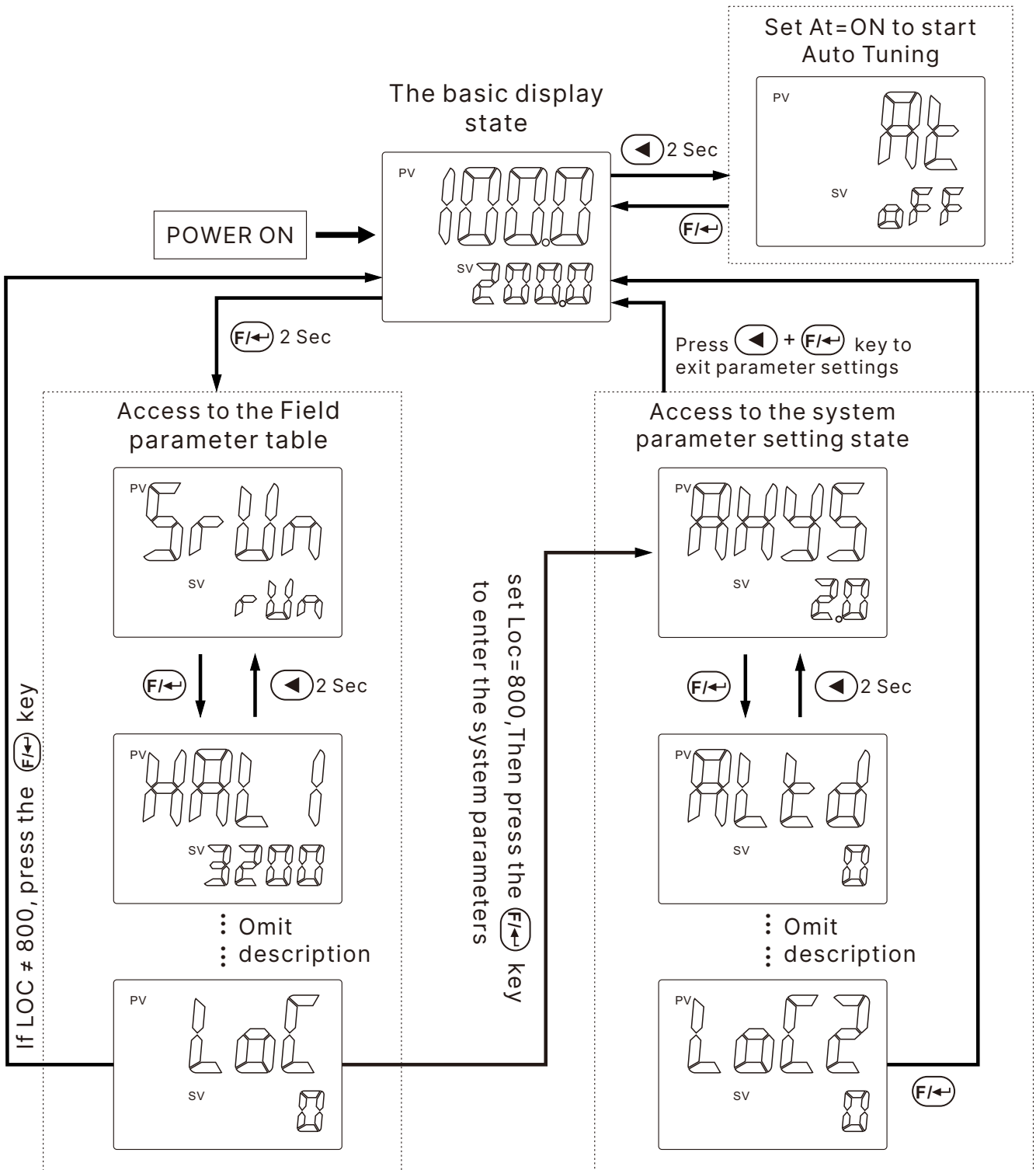

7. Instrument operation method description

7.1 Parameter Setting

In the basic display state, press the $\text{F/}\leftarrow$ key and hold for about 2 seconds to enter the field parameter setting state. If you set LOC=800 and press the $\text{F/}\leftarrow$ key, you can enter the function parameter settings. Press the \leftarrow , \blacktriangle , \blacktriangledown , etc. keys to directly modify the parameter values. Press \blacktriangledown to decrease the data, press \blacktriangle to increase the data. The value waiting to be modified will flash, press and hold, you can quickly increase/decrease the value. You can also press the \leftarrow key to move directly to the value bit you want to modify, and the operation is faster. Press the $\text{F/}\leftarrow$ key to save the modified parameter value and display the next parameter. Press the \leftarrow key and hold it for more than 2 seconds to return to the previous parameter. Press the $\text{F/}\leftarrow$ + \leftarrow keys to directly exit the parameter setting state. If there is no key operation, it will automatically exit the parameter setting state after about 30 seconds.

7.2 Setting the given value

In the basic display state, press the \leftarrow , \blacktriangle , \blacktriangledown keys to directly modify the given value.

7.3 Stop Control

In the basic display state, press and hold the $\text{F/}\leftarrow$ key for about 2 seconds to enter the on-site parameter setting state. Use the \blacktriangle key to set the $SrUn$ (SrUn) parameter to stop. Then press the \leftarrow + $\text{F/}\leftarrow$ keys to directly exit the parameter setting state. At this point, the second display window will display "Stop" and flash, and the instrument will stop controlling the output.

7.4 Run control

If in the basic display state, the second display window of the instrument shows "Stop" and flashes, indicating that the instrument is in a stop control output state. Press and hold the $\text{F/}\leftarrow$ key for about 2 seconds to enter the on-site parameter setting state. Use the \blacktriangledown key to set the $SrUn$ (SrUn) parameter to rUn. Then press the \leftarrow + $\text{F/}\leftarrow$ keys to directly exit the parameter setting state. At this point, the second display window will briefly display "rUn", and the instrument will perform normal run control.

7.5 Auto Tuning

When FUZZY+PID control method is chosen (CntL=FPID), the optimal PID parameters can be obtained by running auto-tuning. So as to achieve precise control without overshoot.

Auto-tuning AT: Press and hold \leftarrow for 2 seconds, the At parameter will appear, press \blacktriangle to change the OFF of the lower display window to on, and then press $\text{F/}\leftarrow$ to confirm to start the self-tuning function. The lower display of the instrument will flash and display the word "At", and the instrument can automatically calculate the PID parameters after 2 oscillation cycles of ON-OFF control. If the auto-tuning is determined to be given up in advance, press \leftarrow again and hold it for about 2 seconds to call up the At parameter, and set on to OFF, and then press $\text{F/}\leftarrow$ to confirm.

Note 1: AiFUZZY artificial intelligence fuzzy logic PID adjustment algorithm combines fuzzy control (FUZZY) and proportional integral derivative (PID) control. It has strong adaptability, good control effect, simple and easy to use, strong robustness, and can maintain stable control performance in uncertain and complex environments. When the instrument chooses AiFUZZY adjustment mode and is used for the first time, the self-tuning function can be activated to assist in determining PID and other control parameters.

Note 2: Note 2: The parameter values obtained by the system tuning under different given values are not exactly the same. Before executing the auto-tuning, the given value SV should be set to the most commonly used value or the middle value, if the system is an electric furnace with good heat preservation performance, the given value SV should be set at the max value used by the system, and it is forbidden to modify the SV value during the self-tuning process. Depending on the system, the time required for auto-tuning can vary from seconds to hours.

Note 3: Note 3: The control effect may not be the best at the end of self-tuning. Due to the self-learning function, the best effect can be obtained after a period of use.

8. Parameter list and function

8.1 Field parameter

In the basic display state, press and hold $\text{F/}\leftrightarrow$ key 2 seconds, Enter the field parameters.

Code	Name	Description	Range
<i>SrUn</i>	Running state	run:Run control state StoP:Stop state, No.2 display flashing display "StoP".	
<i>HAL 1</i>	AL1 high limit alarm value	"HAL1" is the absolute value alarm or deviation value alarm, by "ALtd" parameter definition. When the value set to Max. will disable this function.(3200)	-999~3200 (Ex-factory value HAL1 and HAL2 is 3200, LAL1 and LAL2 is -999)
<i>LAL 1</i>	AL1 low limit alarm value	"LAL1" is the absolute value alarm or deviation value alarm, by "ALtd" parameter definition. When the value set to Min. will disable this function.(-999)	
<i>HAL 2</i>	AL2 high limit alarm value	"HAL2" is the absolute value alarm or deviation value alarm, by "ALtd" parameter definition. When the value set to Max. will disable this function.(3200)	
<i>LAL 2</i>	AL2 low limit alarm value	"LAL2" is the absolute value alarm or deviation value alarm, by "ALtd" parameter definition. When the value set to Min. will disable this function.(-999)	
<i>Loc</i>	Password lock	Set LOC=800, then press the $\text{F/}\leftrightarrow$ key to enter the following system parameters.	

8.2 System parameter

In the field parameters, set Loc=800, Then press $\text{F/}\leftrightarrow$ key to enter the system parameters.

Code	Name	Description	Range
<i>ALYS</i>	Alarm hysteresis	Avoid frequent alarm on-off action because of the fluctuation of PV.	0~200.0 (Ex-factory value 2)
<i>ALtd</i>	Alarm mode	ALtd=0, AL1 is the deviation value alarm, AL2 is the absolute value alarm. ALtd=1, AL1 and AL2 is the absolute value alarm. ALtd=2, AL1 and AL2 is the deviation value alarm.	0~9999 (Ex-factory value 0)
<i>Ctrl</i>	Control mode	onoF: on-off control. For situation not requiring high precision. FPId: advanced artificial intelligence AiFUZZY(FUZZY+PID) control(Recommended use).	Ex-factory value FPId
<i>orEu</i>	Selection of heating refrigeration	onr: Reverse acting. Increase in measured variable causes a decrease in the output, such as heating control. ond: Direct acting. Increase in measured variable causes an increase in the output, such as refrigerating control.	Ex-factory value onr

<i>P</i>	Proportional band	Proportional band in FPID control. Instead of percentage of the measurement range, the unit is the same as PV. Generally, optimal P, I, D and CP can obtained by auto tuning. They can also be manually inputted if you already know the correct values.	1~3200 (Ex-factory value 25)
<i>I</i>	Integration time	The integration time of the FPID adjustment, the unit is sec, and the integral action is canceled when I=0.	1~9999 (Ex-factory value 200)
<i>d</i>	Differential time	The differential time of the FPID adjustment, the unit is 0.1 sec, and the differential effect is canceled when d=0. *d initial value:50.0.	1~3200 (Ex-factory value 50.0)
<i>CP</i>	Control cycle	CP reflect the instrument operator to adjust the speed, the size of the CP that affect the control accuracy. With SSR, SCR output control cycle preferable to shorter, usually 0.5-3.0 Sec. The relay switch output is generally in 15-40 sec. When the output relay switches, the CP will be limited to 3 sec, And self-tuning At will automatically set the CP as the appropriate value, taking into account the control accuracy And mechanical switch life. When the control mode CntL = onof, the action of the CP as an output disconnect or power-on output ON Delay time.	0.2~300.0 (Ex-factory value Relay output is 15.0, SSR output is 2.0)
<i>HYS</i>	Control hysteresis	HYS is used for ON-OFF control to avoid frequent on-off action of relay. For a reverse acting (heating) system, when PV > SV, output turns off; when PV < SV-HYS, output turns on. For a direct acting (cooling) system, when PV < SV, output turns off; when PV > SV+HYS, output turns on.	0~200.0 (Ex-factory value 2.0)
<i>Int</i> (Int)	Input Signal	Selection of input Types for thermocouples or RTD: K,E,J,N,Pt (Pt100)	Ex-factory value K
<i>dP</i>	Decimal point	0 :no decimal. 0.0:one decimal place.	Ex-factory value 0.0
<i>Sc</i>	Input Shift Adjustment	SC is used to shift input to compensate the error caused by transducer, input signal, or auto cold junction compensation of thermocouple. PV after compensation = PV before compensation + Sc It is generally set to 0. The incorrect setting will cause measurement inaccurate.	-199.9~+400.0 (Ex-factory value 0.0)
<i>InF</i>	PV input filter	The value of InF will determine the ability of filtering noise. When a large value is set, the measurement input is stabilized but the response speed is slow. Generally, it can be set to 1 to 3. If great interference exists, then you can increase parameter "InF" gradually to make momentary fluctuation of measured value less than 2 to 5. When the instrument is being metrological verified, "InF" s can be set to 0 or 1 to shorten the response time.	0~40 (Ex-factory value 2)

<i>du</i>	Temperature unit selection	°C: celsius equals °F: fahrenheit equals	Ex-factory Value °C
<i>SPL</i>	Low limit of SV	Minimum value that SV is allowed to be.	-999~3200 (ex-factory Value SPL is -99, SPH is 999)
<i>SPH</i>	High limit of SV	Minimum value that SV is allowed to be.	

9. Partial application wiring methods

9.1 The wiring method of the input signal

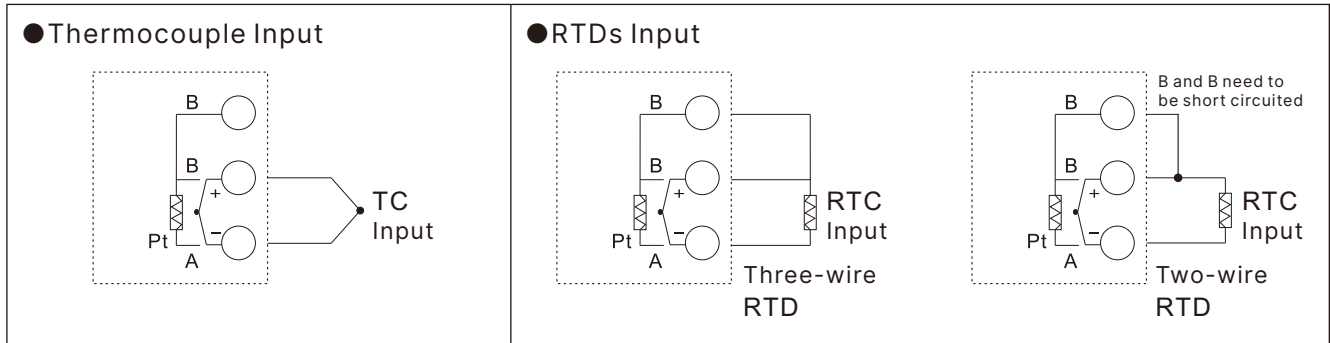

*If the input wiring is incorrect or the sensor is damaged or out of range or the Int setting is inconsistent with the input sensor type, the second display window will display a "orAL" warning flashing. After you eliminate these faults, the instrument will display the measured values normally.

9.2 Main control output wiring method

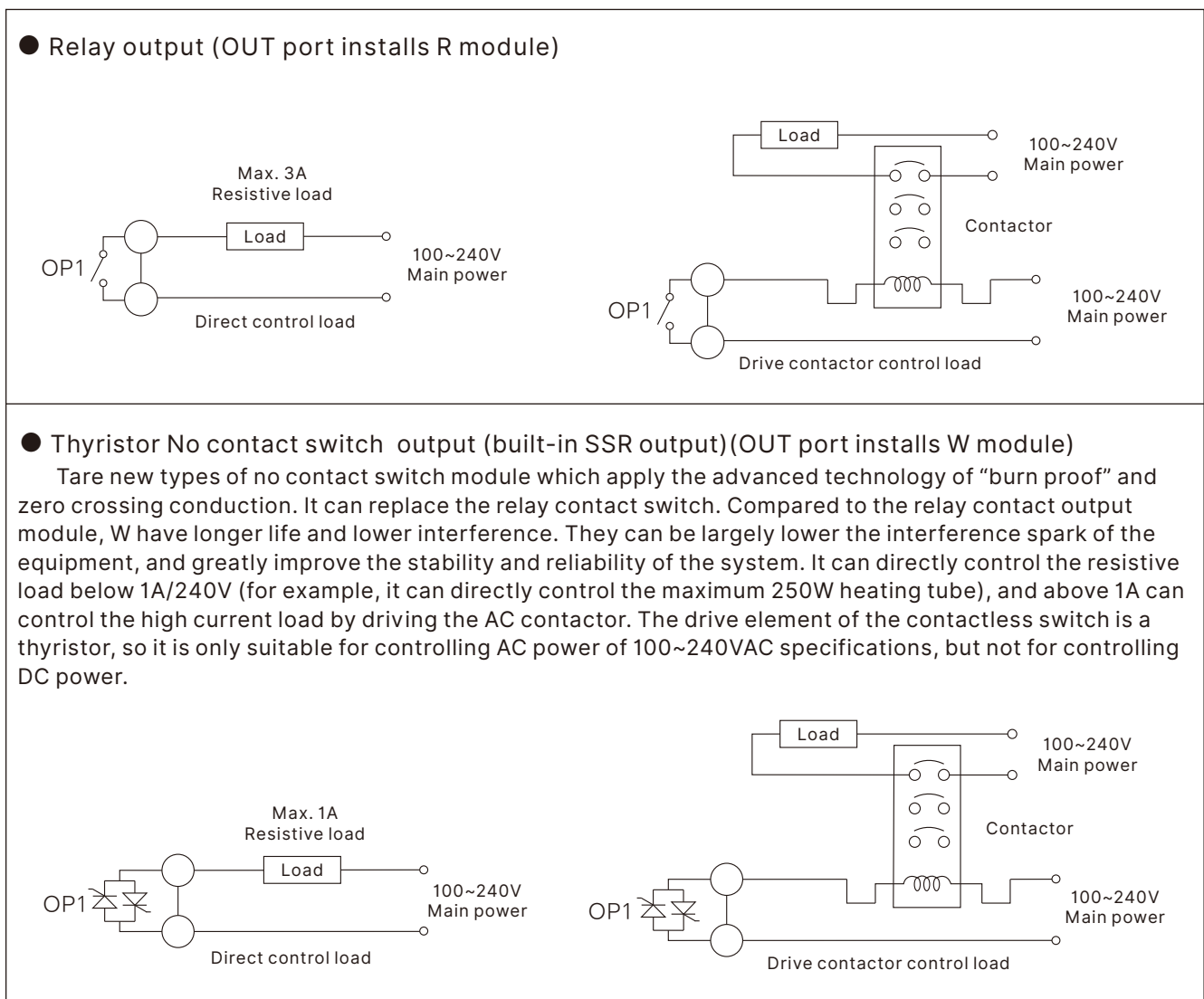

● 12V SSR drive voltage output(OUT port installed Q module)

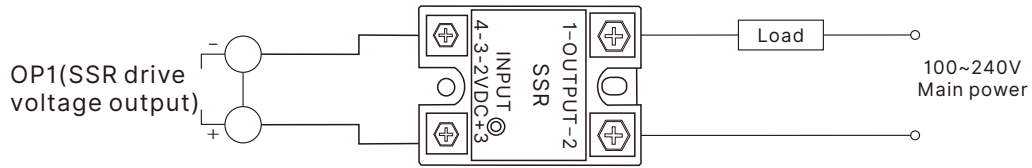

● Built-in SSR direct output load power supply (OUT port installed Q7 module)

Built in SSR solid-state relay, and inside the instrument, the SSR output end is connected in parallel with the instrument power supply end, directly outputting the load power supply (For example, if the instrument power supply is connected to 220V, the output is 220V voltage, and if the instrument power supply is connected to 110V, the output is 110V voltage), suitable for 1.5A/220V small power loads (customized).

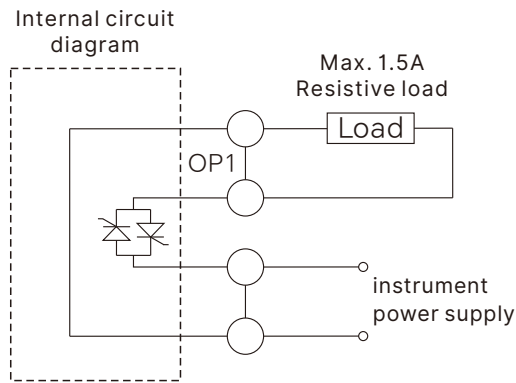

10. Dimensions and installation instructions(mm)

● G-types panel

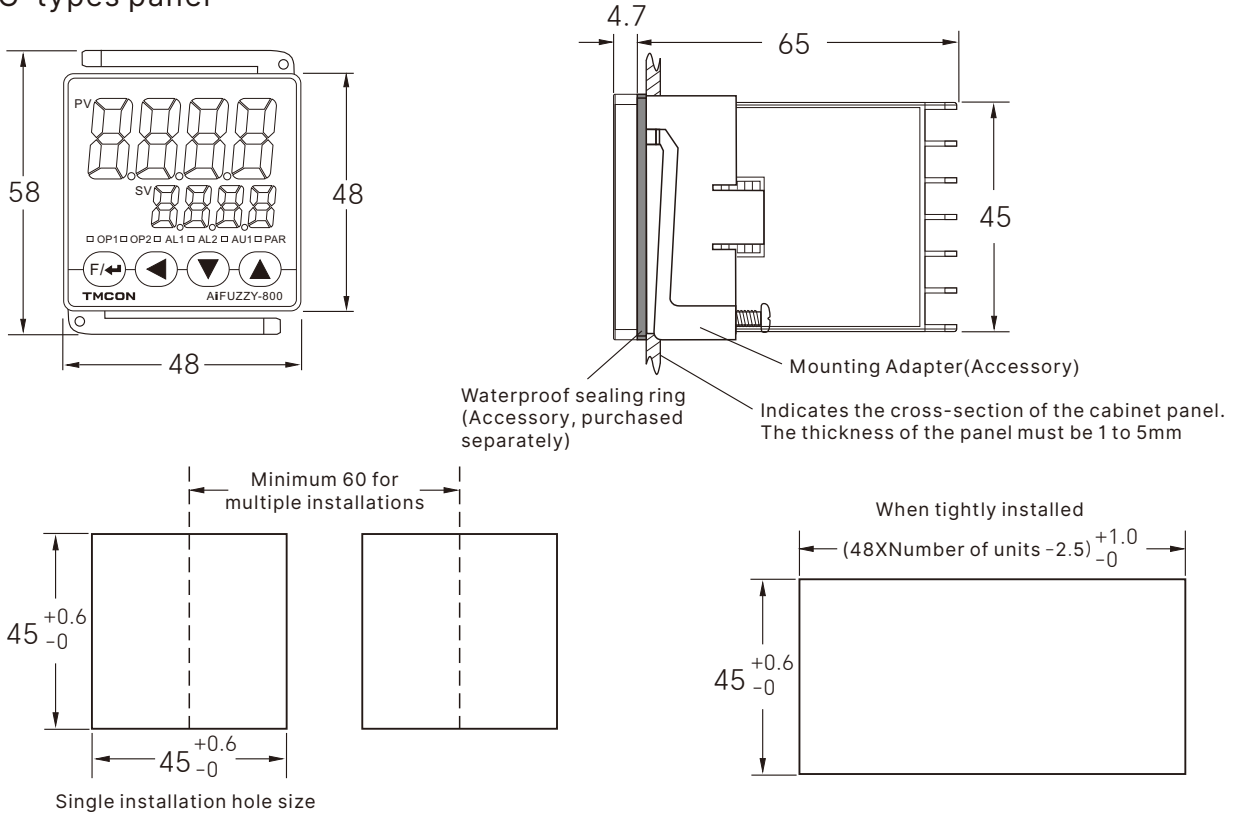

● D-types panel

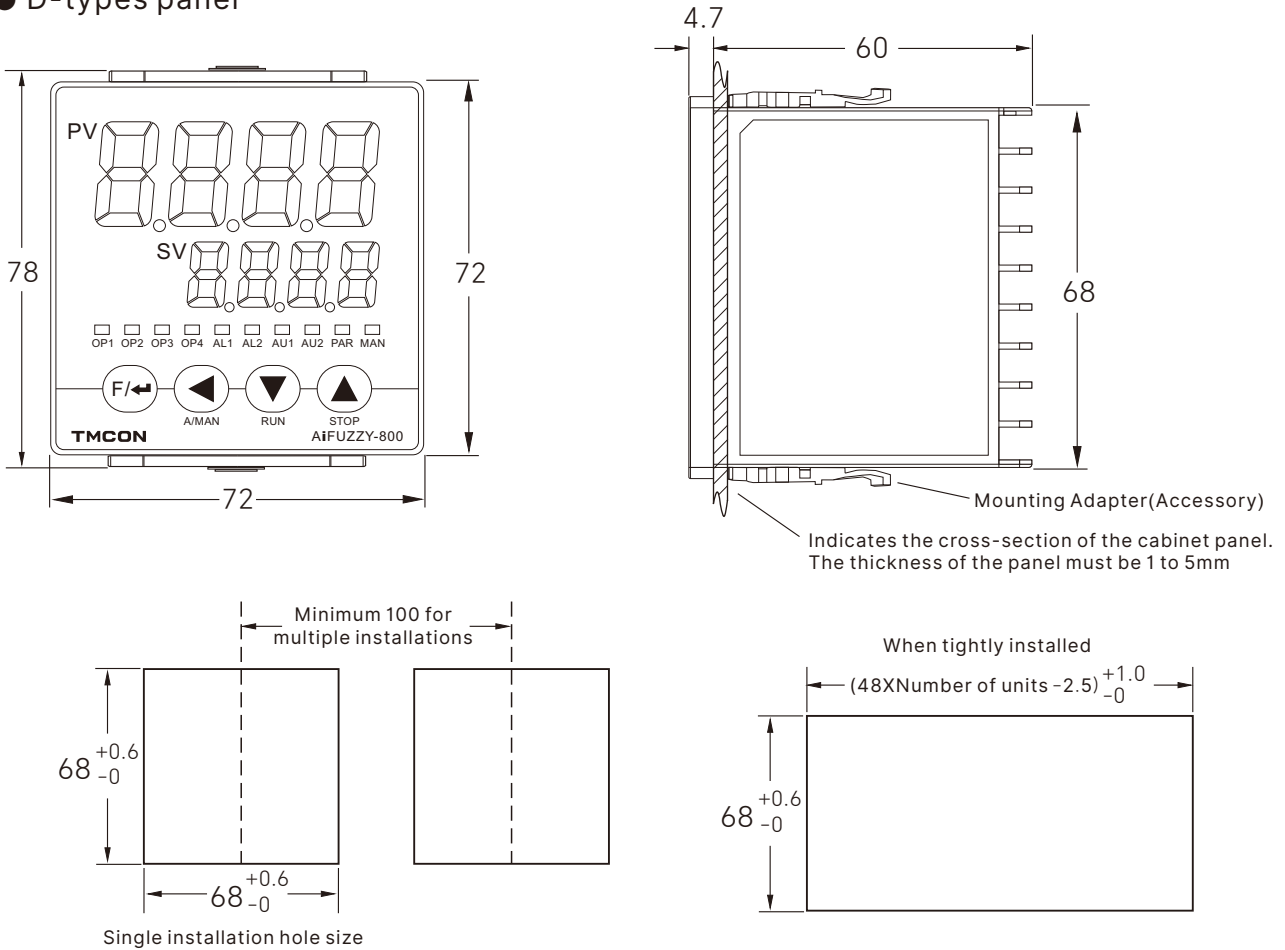

● A-types panel

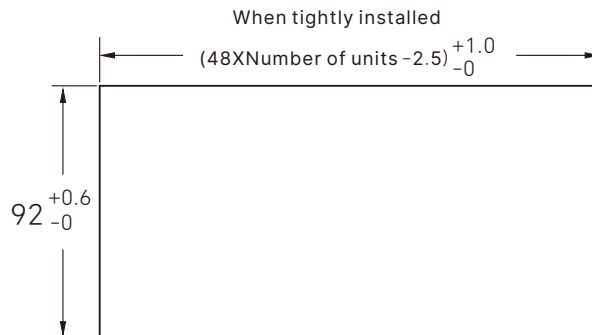
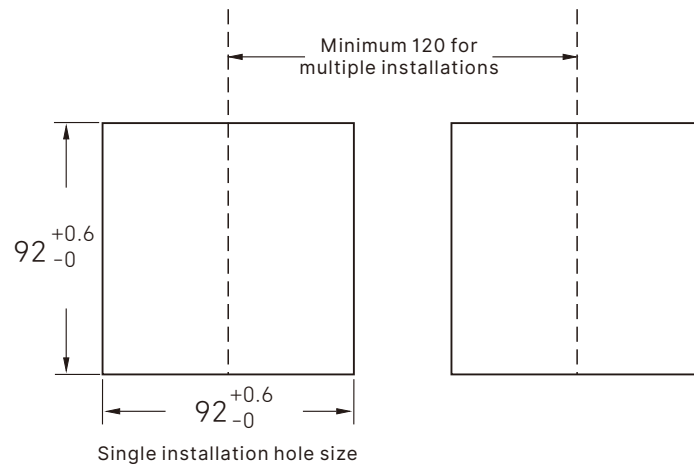
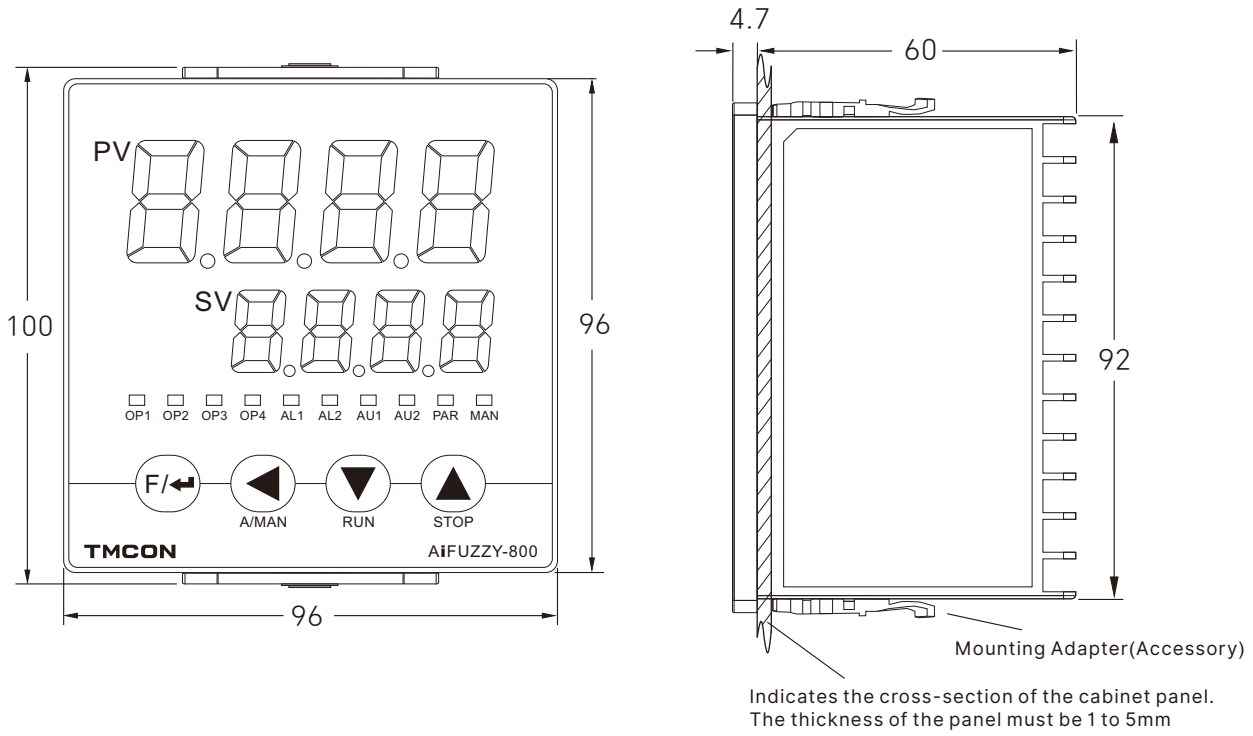

● E-types panel

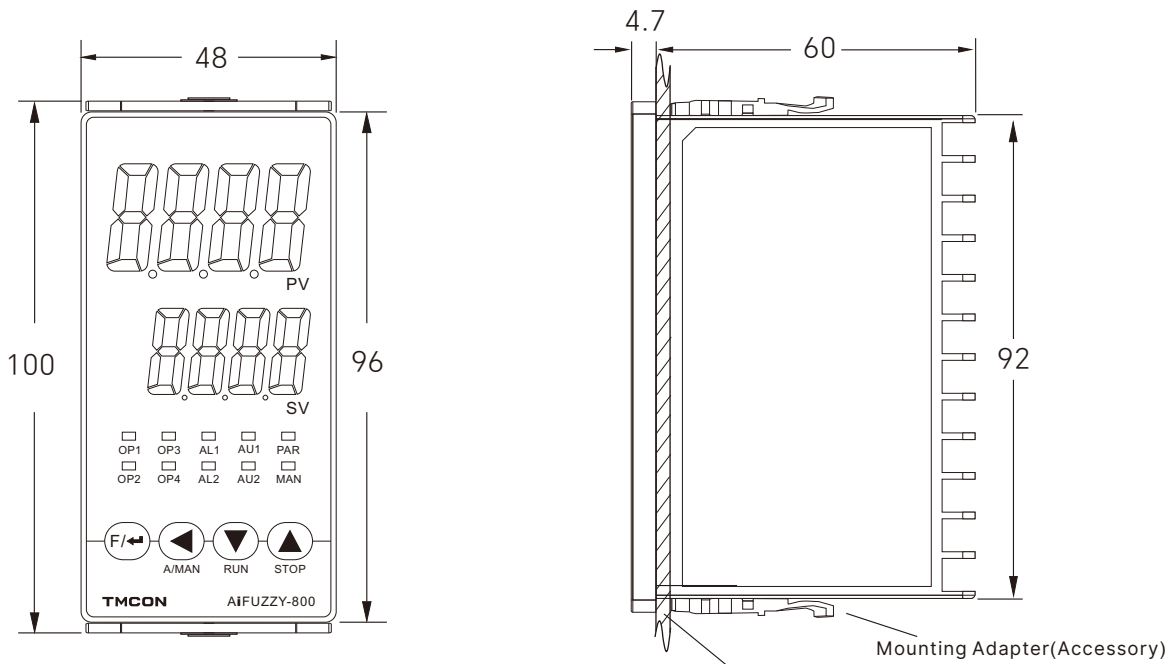

Indicates the cross-section of the cabinet panel.
The thickness of the panel must be 1 to 5mm

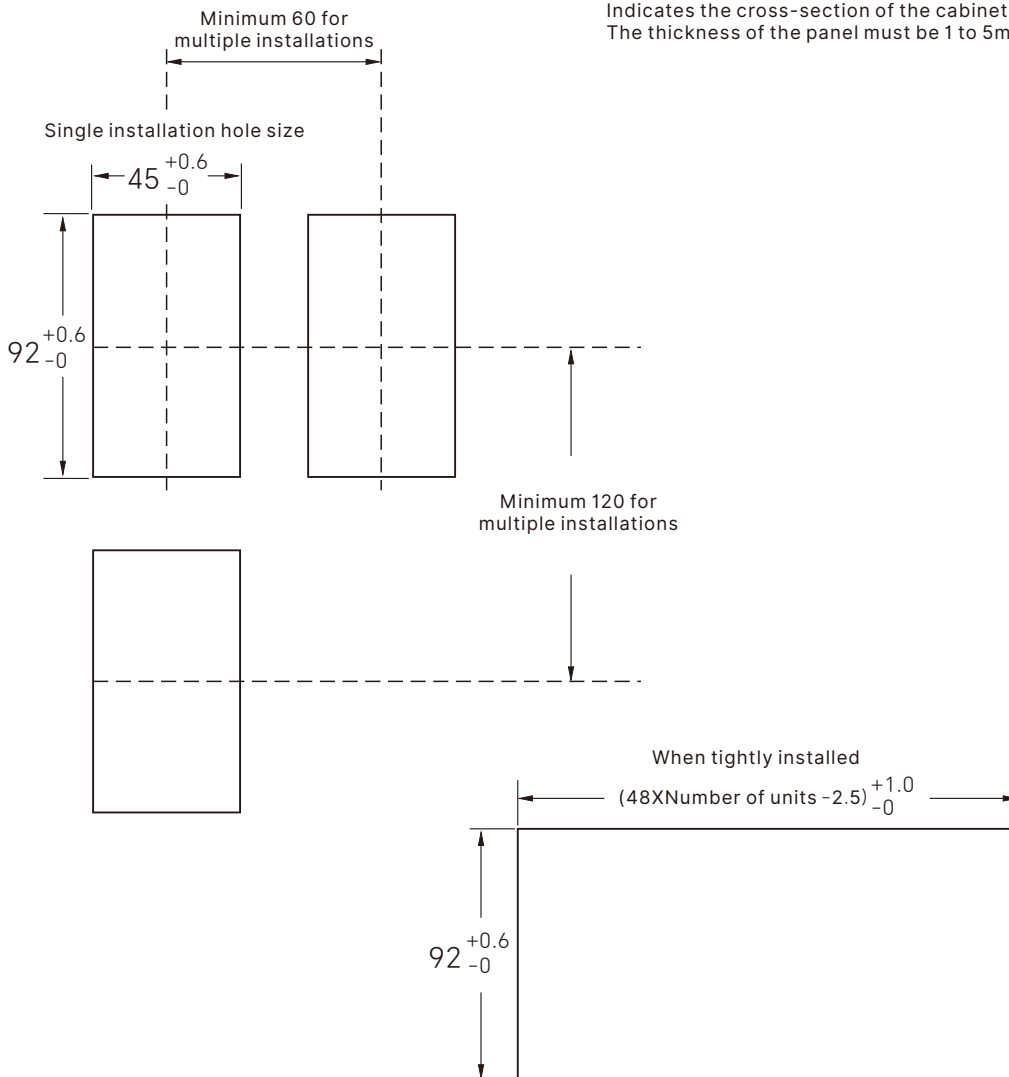

● F-types panel

