

Classic LED display high-performance temperature controller/regulator AiFUZZY-819/879

Technical Manual
Version number: EN-V8-01



About us

Guangzhou Tmcon Electronic Technology Co, Ltd.

Address: No.1, Xinhe Road West Street, Xier Village, Luopu Street, Panyu District, Guangzhou

Email: chinatmcon@163.com

WeChat : +86 13662353011

TEL:+86 13533063770

WhatsApp: +86 13533063770

Alternatively, click on the instant messaging tool on the www.china-tmcon.com website to answer your questions online

Thank you very much for choosing TMCON products,
In order to better use this product, please read the following before using.

Table of contents	Page
Table of contents	1-2
Safety precautions	3
Chapter 1 main features	4
1.1 AiFUZZY819 Main features	4
1.2 AiFUZZY879 Main features	4
Chapter 2 technical parameter	5-6
Chapter 3 model definition	7-8
Chapter 4 wiring diagram	9-10
Chapter 5 panel description	11
Chapter 6 Installation module instructions	12
Chapter 7 Operation Flow Chart	13-14
7.1 Display status and basic operation flow chart	13
7.2 Program Settings flow chart (AiFUZZY-879 only)	14
Chapter 8 Instruction of instrument operation method	15-16
8.1 Parameter setting	15
8.2 Set Value Setting	15
8.3 Setting up the program	15
8.4 Run / Hold	15
8.5 Stop	15
8.6 Automatic/manual control switching (A/M)	15
8.7 Auto Tuning	16
Chapter 9 Parameter table and function	17-28
9.1 Field parameter	17-18
9.2 Function parameter	18-24
9.3 Control parameter	24-28

Table of contents	Page
Chapter 10 Additional remarks of special functions.....	29-32
10.1 Position proportional output	29
10.2 Manual auto-tuning	29
10.3 Single-phase phase-shift trigger output	30
10.4 Dead zone	30
10.5 Temperature re-transmitter / Program generator / Manual current output.....	30
10.6 External signal remote control SV set value	30
10.7 Alarm delay diagram	31
10.8 Alarm self - locking.....	31
10.9 First alarm exemptions	31
10.10 LBA Control loop break off / shorted Alarm	31
10.11 Fine Control	32
10.12 Communication function	32
Chapter 11 Partial application wiring methods.....	33-35
11.1 The wiring method of the input signal	33-34
11.2 Main control output wiring method	34-35
Chapter 12 Input fault indication	36
Chapter 13 Further explanation of AiFUZZY-879 program control	37-40
13.1 Function and Concept	37-38
13.2 Programming and operation (For AiFUZZY-879 only)	38-40
13.2.1 Ramp mode	38-39
13.2.2 Platform Mode	39
13.2.3 Set the given value and time of the program	39
13.2.4 Multi-group PID application case	39-40
13.2.5 Auto-tuning program setting method	40
Chapter 14 Dimensions and installation instructions	41-44

■ Safety precautions

Attention

Minor injury due to electric shock may occasionally occur.
Do not touch the terminals while power is being supplied.



Electric shock, fire, or malfunction may occasionally occur.
Do not allow metal objects, conductors, debris (such as cuttings) from installation work, moisture, or other foreign matter to enter the Digital Controller, the Setup Tool ports, or between the pins on the connectors on the Setup Tool cable.
Attach the cover to the front-panel Setup Tool port whenever you are not using it to prevent foreign objects from entering the port.



Minor injury from explosion may occasionally occur.
Do not use the product where subject to flammable or explosive gas.



Minor electric shock or fire may occasionally occur.
Do not use a Digital Controller or any cables that are damaged.



Minor electric shock, fire, or malfunction may occasionally occur.
Never disassemble, modify, or repair the product or touch any of the internal parts.



CAUTION - Risk of Fire and Electric Shock

- (a) This product is UL listed as Open Type Process Control Equipment. It must be mounted in an enclosure that does not allow fire to escape externally.
- (b) More than one disconnect switch may be required to de-energize the equipment before servicing.
- (c) Signal inputs are SELV, limited energy.*1
- (d) Caution: To reduce the risk of fire or electric shock, do not interconnect the outputs of different Class 2 circuits.*2



If the output relays are used past their life expectancy, contact fusing or burning may occasionally occur. Always consider the application conditions and use the output relays within their rated load and electrical life expectancy.
The life expectancy of output relays varies considerably with the output load and switching conditions.



*1 An SELV (separated extra-low voltage) system is one with a power supply that has double or reinforced insulation between the primary and the secondary circuits and has an output voltage of 30 V r.m.s. max. and 42.4 V peak max. or 60 VDC max.

*2 Class2 power supply refers to a power supply where the current and voltage are respectively limited to a certain level for testing in the secondary output of the product.

■ 1. Main features

1.1 AiFUZZY819 Main features

- Adopting a color LCD display screen, the PV white font is easy to read from a long distance, and the side illuminated backlight is paired with an advanced LCD display screen, resulting in a soft and clear display effect.
- The ultra-thin panel and large screen LCD are paired with a new trend industrial aesthetic shell , giving a more advanced feel.
- Plastic handle waterproof button, the surface of the button is sturdy and wear-resistant, and the operating feel is clear and smooth.
- Universal input, through the parameter setting can be freely to select thermocouple, thermal resistance, analog linear voltage and current input signals.
- There are many output module specifications to choose from: relay contact switch output module, SSR drive voltage output module, SCR non-contact switch output module, One-way/ three-way SCR zero-crossing trigger output module, one-way SCR phase-shift trigger output module , analog linear voltage and current output module, valve motor dedicated output module.
- Breakthrough higher accuracy, with a measurement accuracy of 0.1 level, the measurement display is accurate and stable.
- AiFUZZY artificial intelligence adjustment algorithm perfectly combines fuzzy control and adaptive PID control, with AT self -setting and AT self -learning functions, It can automatically learn and remember some features of the controlled object during adjustment to optimize the effect. It has the control characteristics without overshoot and undershoot adjustment, and can also obtain excellent control effects on complex and difficult control objects.
- Free definition of designated alarm ports and alarm methods, and up to 4 alarm outputs can be formed.
- MIO auxiliary input can be optionally equipped with external switch signal input, which can achieve dual temperature set value switching or RUN/STOP switching or double PID parameter switching.
- In addition to the standard one-way heating PID control or one-way cooling PID control, it can also achieve dual PID dual control outputs for heating/cooling. The heating PID and cooling PID automatically switch based on the set value.
- It has the function of freely defining Rate limiting of temperature rise and drop.
- Equipped with manual/automatic undisturbed switching function, it can be used as a manual operator.
- It can achieve external analog signal input to set the temperature set value and form a cascade control.
- The measured value (PV) or given value (SV) can be converted into an analog linear current signal output.
- It can simultaneously have one PID control output and one PV value transmission output function.
- When the instrument has multiple sets of input and output, it can provide a comprehensive power supply and optoelectronic isolation solution.
- RS485 communication interface or RS232 communication interface is optional, support MODBUS-RTU communication protocol, 10ms fast communication response, unlimited write times, do not need to worry about communication write life, and can cooperate with our wireless communication module to achieve a variety of wireless transparent transmission network connection mode such as TCP.
- The power supply adopts a self-healing circuit design, which can automatically cut off power to protect the instrument in case of overvoltage or undervoltage. When the voltage is normal, it can automatically restore normal power supply.

1.2 AiFUZZY979 Main features

- AiFUZZY879 adds an 80 segment program control function on top of the high-performance AiFUZZY-819 temperature controller. AiFUZZY879 program type instrument is used in situations where it is necessary to automatically change the set value for control according to a certain time rule. It not only has the function of 80 segments programming, which can set the rise and fall slope of any given value, but also has programmable/operable commands such as jump, run, pause and stop, which can modify the program during program control operation; in addition, it has power failure processing mode, measured value startup function and preparation function as well, which makes program execution more efficient and perfect.

2. Technical Parameter

type	G - type panel	D - type panel	A - type panel	E - type panel	F - type panel
Panel size (wide × high)	48×48mm	72×72mm	96×96mm	48×96mm (Vice)	96×48mm (Horizontal)
Open -hole size (wide × high)	45×45mm	68×68mm	92×92mm	45×92mm	92×45mm
Installation method	Embedded panel installation				
Power supply	AC100~240V 50/60Hz; or DC12~24V				
Allow the range of voltage changes	85%~ 110%of the rated power voltage				
Power consumption	About 5VA when AC100 ~ 240V, and about 3.5VA at DC24V				
Display method	7 -segment LED digital display and separate indicators				
Input specification	Thermocouple input: K, S, R, T, E, J, B, N, WRe3-WRe25, WRe5-WRe26, etc Thermal resistance input: CU50, PT100 Linear voltage input: 0-5V, 1-5V, 0-1V, 0.2-1V, 0-20mV, 0-60mV, 0-75mV, 0-100mV, -5-+5V, -20mV-+20mV, -100-+100mV, etc Linear current input: 0 - 20mA, 4-20mA, etc				
Measuring range	K (-50 ~+1300°C), S (-50 ~+1700°C), R (-50 ~+1700°C), T (-200 ~+350°C) , E (0 ~ 800°C), J (0 ~ 1000°C), B (200 ~ 1800°C), N (0 ~ 1300°C), Cu50 (-50 ~+150°C), Pt100 (-200 ~+600°C) Linear input: -9990 ~+32000 defined by users				
Decimal point	0000, 000.0, 00.00, 0.000 (set by DP parameters)				
measurement accuracy	Level 0.1				
The sampling period	Sample 10 times per second; set the digital filter parameter INF = 0, the response time ≤ 0.5 seconds				
control method	1.ON/OFF Position adjustment method (adjustable hysteresis) 2.AiFUZZY artificial intelligence adjustment, advanced control algorithm including fuzzy logic PID adjustment and parameter self-tuning function, 3.PV value transmit 4.SV value transmit				
Control cycle	0.1 ~ 300.0 seconds adjustable				
Relay contact switch output	3A/20VAC or 3A/30VDC				
SSR voltage output	12VDC 50mA or 9VDC 50mA (for driving SSR solid -state relay)				
SCR non-contact output module	100~240VAC/0.2A (continuous); 2A (20mS momentary, 5S repetition period)				
SCR trigger output	Can trigger 5~500A bidirectional SCR, 2 unidirectional SCR anti-parallel connection or SCR power module				
Linear current output	0-20mA or 4-20mA can be freely defined (output voltage ≥ 10.5V)Panel				

Electromagnetic Compatibility	IEC61000-4-4 (electrical fast transient burst) $\pm 6\text{KV}/5\text{KHz}$, IEC61000-4-5 (surge) 6KV, and under the interference of 10V/m high-frequency electromagnetic field, the instrument does not crash, the I/O malfunctions will not emerge either, and the fluctuation of the measured value does not exceed $\pm 5\%$ of the range
Isolation withstand voltage	The power supply side, the relay contact and the signal side are $\geq 2300\text{VDC}$; the interdependent weak electricity signal end $\geq 600\text{VDC}$
Use environment	Temperature $-10 \sim +60^\circ\text{C}$ (not freezing or exposed), humidity 25-85%RH
Storage environment	Temperature $-25 \sim +70^\circ\text{C}$ (not freezing or exposed), humidity 25-85%RH

3.Model definition

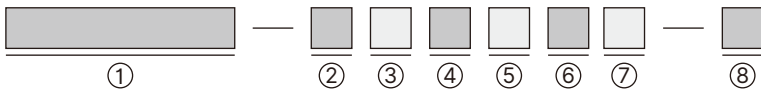

①	②	③	④	⑤	⑥	⑦	⑧	
Model	Panel size	MIO Auxiliary input port	OUTP Control output	ALM Alarm output	AUX Control output	COMM Communication Interface	Meter power supply	
AiFUZZY819	G	N	N	N	N	N	N or not write	
AiFUZZY879	D	I2	R1	R1	R1	S	D	
	E	I3	Q1	R2	R2	S2		
	F	I4	W1	R3	R3	S4		
	A	V5	W2	Q1	Q1	Q1		X2
		V12	X2	Q2	Q2	Q2		V5
		V24	X5		W1	W1		V12
			X8		W2	W2		V24
			K1		X2	X2		
			K3		X5	X5		
			K5		X8	X8		
	K6		K1	K1				
	Q7		V5	V5				
			V12	V12				
			V24	V24				

① Model

Code	illustrate
AiFUZZY819	Classic LED display high -performance multifunction temperature controller/regulator
AiFUZZY879	Classic LED display high-performance programmable temperature controller/regulator (AiFUZZY879 adds an 80 segment program control function on top of the AiFUZZY-819)

② Indicates the size of the meter

Code	illustrate
G	Panel size 48 × 48mm (wide × high), open hole size 45 × 45mm
D	Panel size 72 × 72mm (wide × high), open hole size 68 × 68mm
E	Panel size 48 × 96mm (wide × high) (vertical), open hole size 45 × 92mm
F	Panel size 96 × 48mm (wide × high) (horizontal), open hole size 92 × 45mm
A	Panel size 96 × 96mm (wide × high), opening size 92 × 92mm

③ ~ ⑦ Module code control table

Code	illustrate
N	No install touch block
I2	Switch / frequency signal input interface can be used for external switching or frequency signal input
I3	Analog 4-20mA/0-20mA input module

I4	Analog 4-20mA/0-20mA input interface module with 24V feed (24VDC/30mA internal series power supply for two-wire transmitter)
R1	Single circuit relay normally open contact switch output module, module capacity: 30VDC/3A, 250VAC/3A
R2	Double -road relay often turn on contact switch output module, module capacity: 30VDC/3A, 250VAC/3A
R3	Single relay frequently open+normal closed contact switch output module, module capacity: 30VDC/2A, 250VAC/2A
Q1	SSR Solid-state relay drive voltage output module, 12VDC/50mA
Q2	Double -road SSR solid -state relay drive voltage output module, dual -road 12VDC/50mA
W1	Normally open thyristor contactless output module, capacity: 100-240VAC/0.2A, with the characteristic of "not burnt out"
W2	Normally closed thyristor contactless output module, capacity: 100-240VAC/0.2A, with the characteristic of "not burnt out"
X2	0-20mA/4-20mA photoelectric isolation programmable linear current output module
X5	Programmable linear voltage output module with 0-5V/1-5V photoelectric isolation
X8	Programmable linear voltage output module with 0-10V/2-10V photoelectric isolation
K1	One-way "not-burn-out" SCR zero-crossing trigger output module, each can trigger 5~500A bidirectional or two anti-parallel one-way SCR.
K3	Three-way "not-burn-out" SCR zero-crossing trigger output module, each can trigger 5~500A bidirectional or two anti-parallel one-way SCR.
K5	One-way 220VAC "not-burn-out" one-way SCR phase-shift trigger output module.
K6	One-way 380VAC "not-burn-out" one-way SCR phase-shift trigger output module.
Q7	Built -in SSR solid -state relay, and interconnect in the instrument and the power supply of the instrument, directly output the power supply voltage module (for example, the power supply is connected to 220V, the output 220V voltage, the power supply is 110V, the output 110V voltage), suitable for 1.5A/220V small small small Power load (customized)
S	RS485 Optical isolation communication interface module
S2	Optical isolation RS232 communication interface module
S4	Optical isolation RS485 communication interface module with its own isolation power supply
V5	The non -isolated 5V DC voltage output module can be used for external transmitters or other circuits, with a maximum current of 50mA
V12	The isolation 12V DC voltage output module is available for external transmitters or other circuits, with a maximum current of 50mA
V24	The isolation 24V DC voltage output module is available for external transmitters or other circuits, with a maximum current of 50mA

⑧ Indicates the power supply power supply

Code	illustrate
N or not write	100~240VAC power supply
D	12-24VDC power supply

4. Wiring diagram

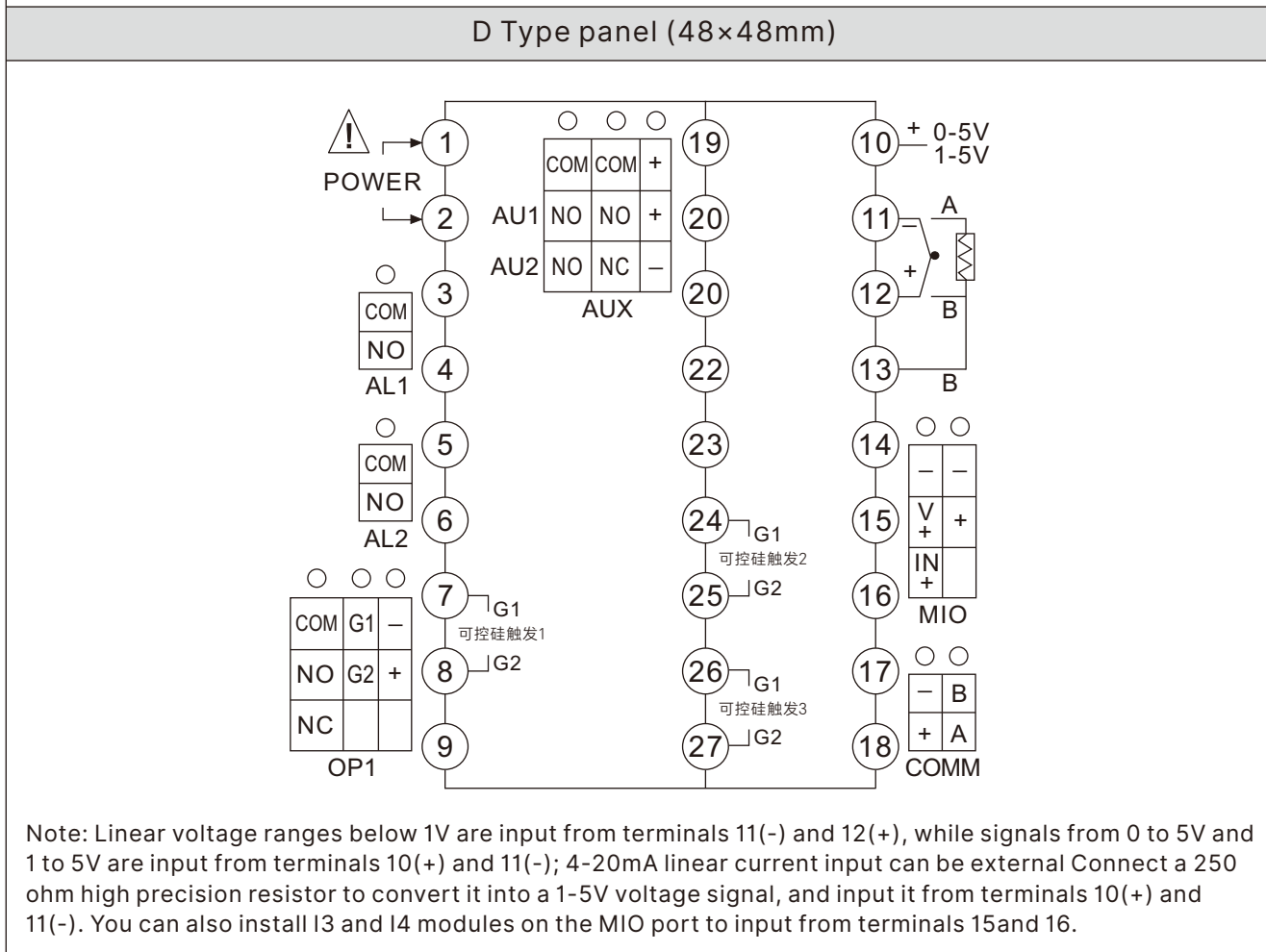
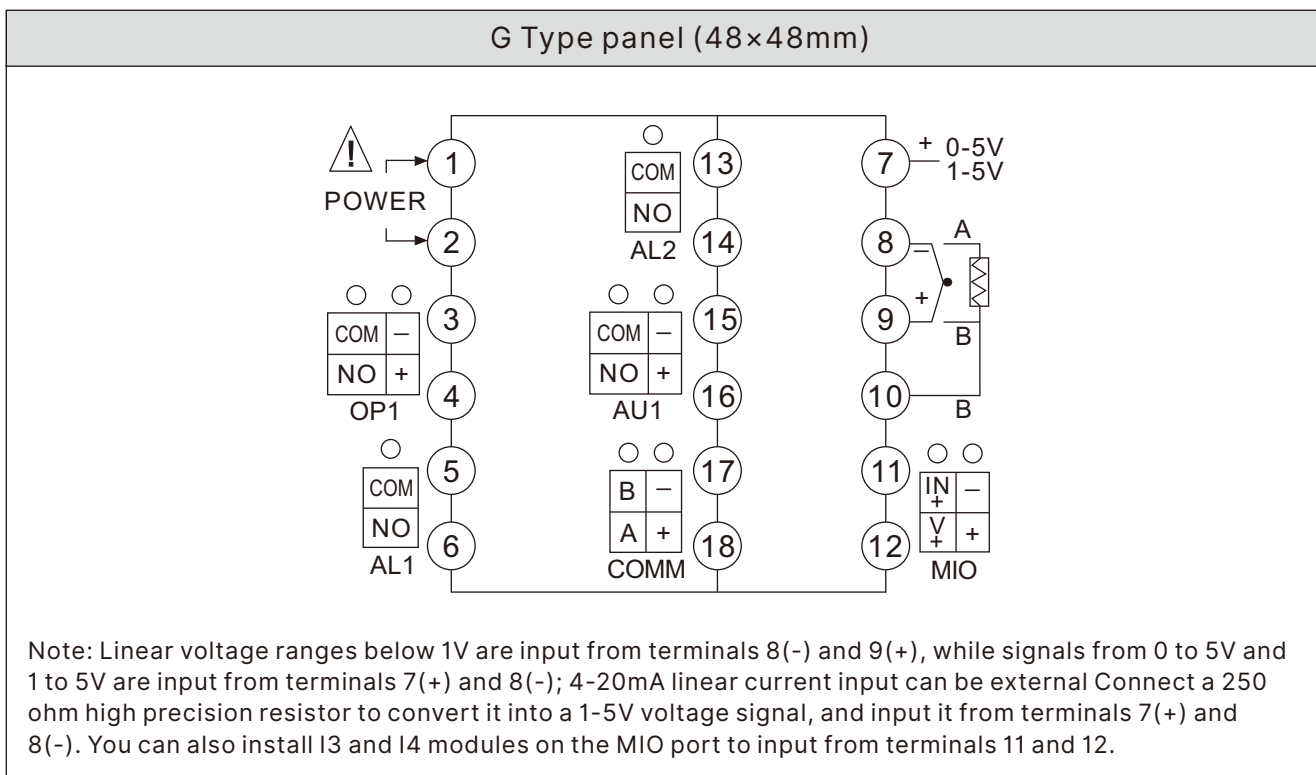

E,F,A Type panel (48×96mm/96×48mm/96×96mm)

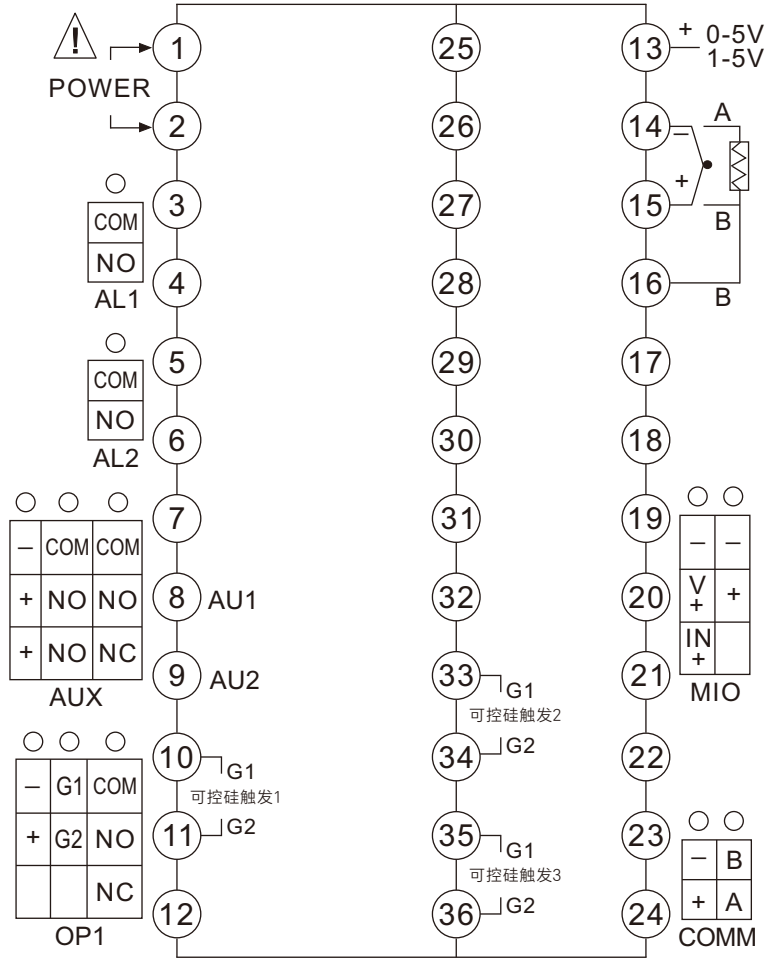

Note: Linear voltage ranges below 1V are input from terminals 14(-) and 15(+), while signals from 0 to 5V and 1 to 5V are input from terminals 13(+) and 14(-); 4-20mA linear current input can be external Connect a 250 ohm high precision resistor to convert it into a 1-5V voltage signal, and input it from terminals 13(+) and 14(-). You can also install I3 and I4 modules on the MIO port to input from terminals 20 and 21.

This wiring diagram visually conforms to the viewing of A and E type panels, while the F type panel is a horizontal panel,Visually, it is necessary to rotate 90 degrees counterclockwise according to this wiring diagram to view, and the terminal number remains unchanged

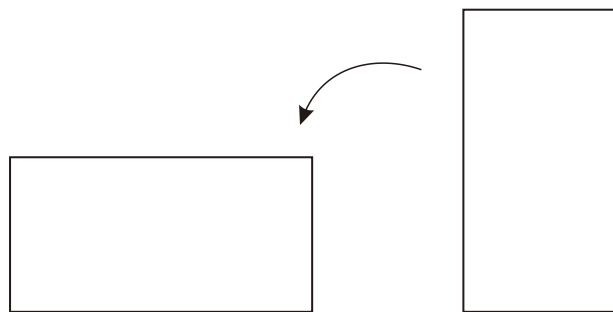

■ 5. Panel description

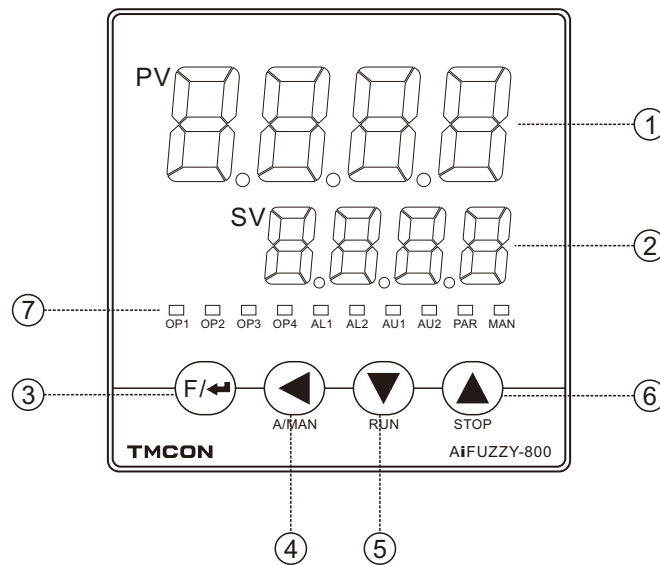

- ① First display window(upper display window) displays the measured value PV, parameter name, etc.
- ② Second display window(The lower display window) displays the given value SV, alarm code, parameter value, etc.
- ③ Set key, used to enter parameter setting status, confirm parameter modification, etc.
- ④ Data shift key (Also as manual/automatic switching and program setup key).
- ⑤ Data decrease key(Also as run key).
- ⑥ Data increase key(Also as stop key).
- ⑦ Output indicator lights, corresponding to module output action indicators.

■ 6. Installation module instructions

AiFUZZY-819/AiFUZZY-879 instrument can have up to five optional function module ports, through the installation of different modules, can achieve different types of output specifications and functional requirements.

Auxiliary Input (MIO): As an extension input or event input or feed output or extension output function, it can be installed with I4 module (internally connected with a 24V power supply, specifically for 4-20mA two wire transmitter input), I3 module (conventional 4-20mA input, internally not connected with a 24V power supply), I2 module (switch signal event input, allowing the instrument to use external switches to achieve dual set value SP1/SP2 switching, or to achieve RUN/STOP switching function, etc.), V module (DC voltage output, available for external transmitters or other circuits).

Main output (OUT): As an ON-OFF control output, FPID (PID+FUZZY) artificial intelligence adjustment output; It can also serve as a measurement value or a given value transmission output function. R module (relay contact output), Q module (SSR drive voltage output), W module (thyristor contactless output), X module (linear current and voltage output), K module (SCR zero crossing trigger, SCR phase shift trigger output) can be installed.

Alarm Output (ALM): As an alarm output function, an R module can be installed (installing R1 can achieve AL1 alarm relay output, and installing R2 can achieve AL1+AL2 alarm relay output).

Auxiliary output (AUX): As the second output (refrigeration PID control output) of the heating and cooling bidirectional dual PID control or as an alarm output, it can be installed with R module, Q module, X module, K (only K1 can be selected) module, and V module.

Communication Interface (COMM): As an RS485 or RS232 communication or PV value transmission output function, it can be installed with S module (communication module), X (linear current and linear voltage as transmission output), and V module (DC voltage output, which can be used for external transmitters or other circuits).

Note: The module is fixed to the PCB by soldering before leaving the factory according to the user's requirements when ordering, and the corresponding parameters are correctly set.

7.Operation Flow Chart

7.1 display status and basic operation flow chart

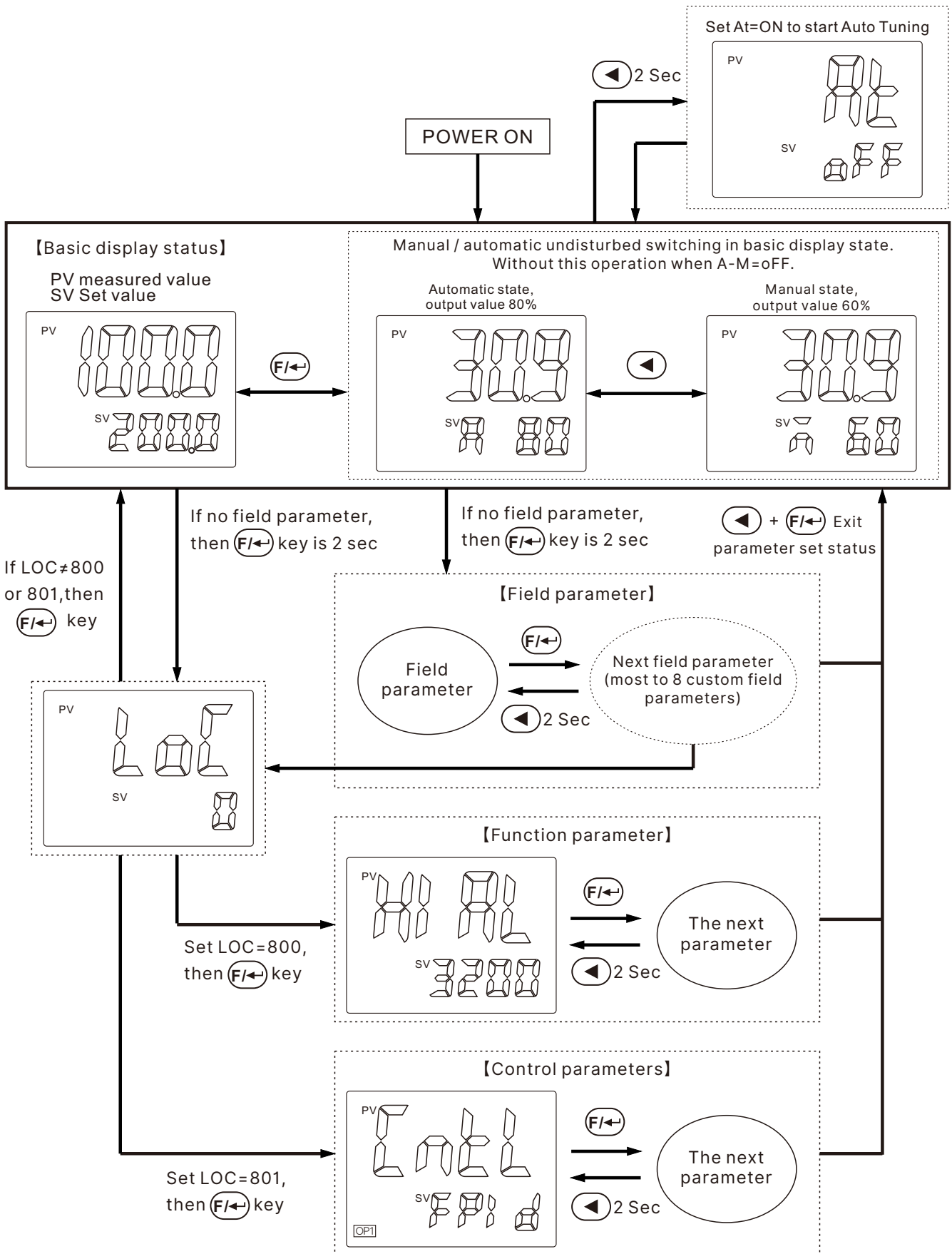

7.2 Program Settings flow chart (AiFUZZY-879 only)

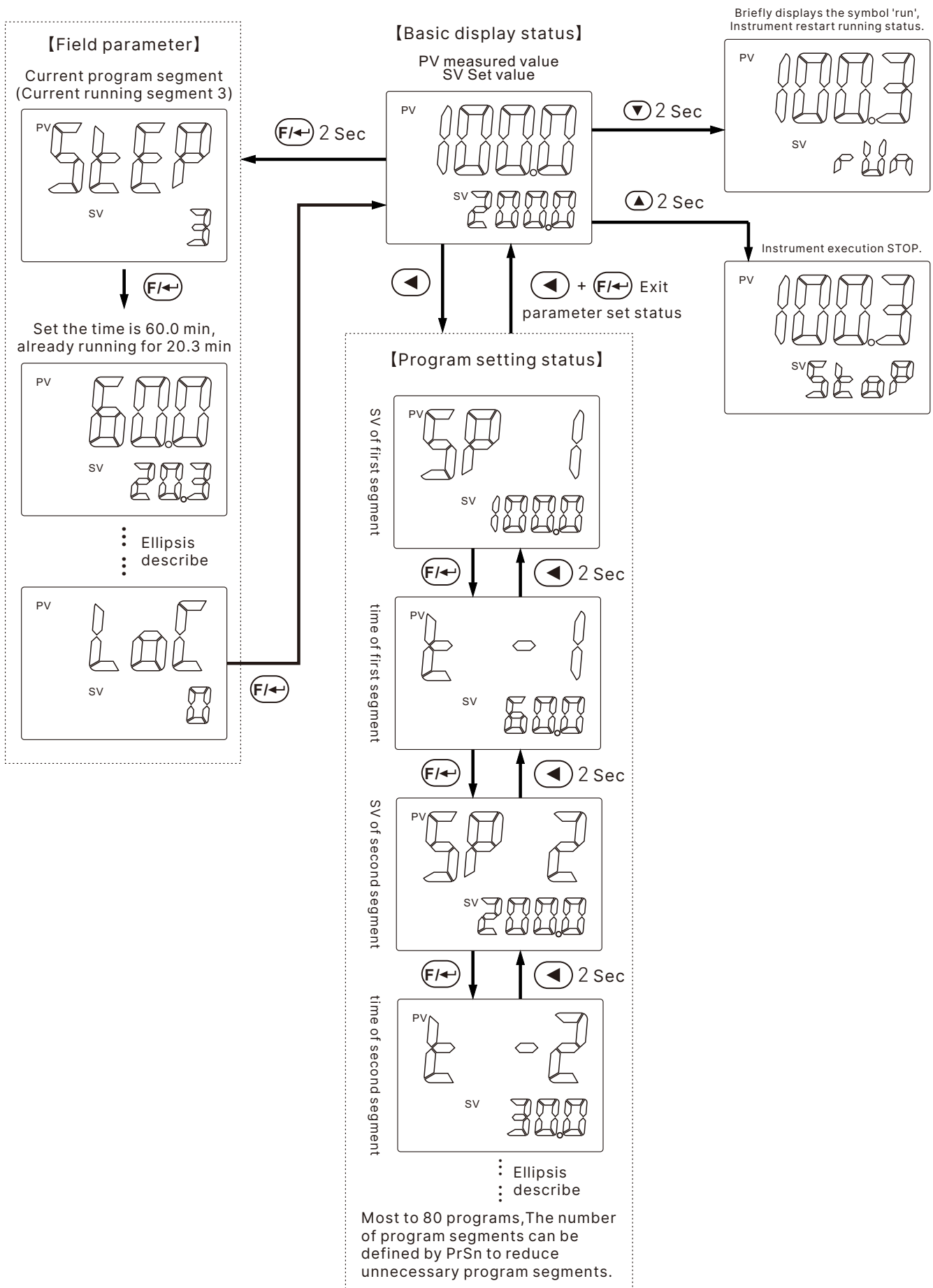

8. Instruction of instrument operation method

8.1 Parameter Setting

In the basic display state, press the $\text{F}(\leftarrow)$ key and hold for about 2 seconds to enter the field parameter setting state. If you set LOC=800 and press the $\text{F}(\leftarrow)$ key, you can enter the function parameter settings. If you set LOC=801 and press the $\text{F}(\leftarrow)$ key, you can enter the control parameter settings. press the \leftarrow , \uparrow , \downarrow , etc. keys to directly modify the parameter values. press \downarrow to decrease the data, press \uparrow to increase the data, The value waiting to be modified will flash, press and hold, you can quickly increase/decrease the value. You can also press \leftarrow key to move directly to the value bit you want to modify, and the operation is faster. press the $\text{F}(\leftarrow)$ key to save the modified parameter value and display the next parameter. press the \leftarrow key and hold it for more than 2 seconds to return to the previous parameter. press the $\leftarrow + \text{F}(\leftarrow)$ key to return to the basic display state.

8.2 Set Value Setting

AiFUZZY-819 or 879 use fixed-point control mode (when parameter PrSn=0), when the Second display window the basic display state of the given value status (if the second display window displays the output value, press $\text{F}(\leftarrow)$ to switch to the given value display), Press \leftarrow to enter the current setpoint status, and then press \leftarrow , \uparrow , \downarrow to directly modify the setpoint.

8.3 Setting up the program

The controller uses the program control mode (when the PrSn \geq 1), in the state that the second display window displays the given value, press the \leftarrow key to enter the program setting state, first display the current running segment program set value, press $\text{F}(\leftarrow)$ Key to display next data, each program is arranged in the order of "program set value - time - program set value".

8.4 Run / Hold

In basic display status, if the program is in stop status ("StoP" is alternately dCisplayed on the second display window), press and hold the \downarrow key for about 2 sec until the second display window displays the "Run" symbol, the instrument then will start the program.

For the 879 instrument, when the F value of parameter PSYS=1, user can hold the \downarrow key for about 2 sec, instrument will changes to hold status and lower display window displays the "HoLd" symbol. If parameter "PSyS" set F=0, "Hold" status only can activate by parameter setting (Srun).

At Hold status, the program is still executing, and the process value is controlled same as set, but the timer stop working, and the running time and setpoint remains. At Hold status, press and hold the \downarrow key for about 2 econds until the second display window displays the "Run" symbol, the instrument will back to run program.

8.5 Stop





Press and hold the \uparrow key for about 2 seconds in the basic display status, until the second display window displays the "stoP" symbol, means the stoP operation is executed now, when program stopped, timer will be reset and stop. This operation forces the instrument to stop running, meanwhile, the StEP number will reset to 1, and control output is also stopped.

8.6 Automatic/manual control switching (A/M)

Automatic/manual control switching (when A-M=AUTO, MAN, or FMA): The second display window displays the output value status, if the second display window displays the given value, you can press the $\text{F}(\leftarrow)$ key to switch to the output value display status, and then press the A/M key (i.e. the \leftarrow key) to make the instrument switch between automatic and manual without disturbance. When in manual mode and the output value is displayed in the second display window, you can directly press the \uparrow key or \downarrow key to increase or decrease the manual output value. By setting the A-M parameters (when A-M=OFF), the instrument can be fixed in automatic mode and cannot be switched to manual mode by panel button operation, in order to prevent accidental entry into manual mode.

8.7 Auto Tuning

When FUZZY+PID control method is chosen (CntL=FPID), the optimal PID parameters can be obtained by running auto-tuning, So as to achieve precise control without overshoot.

Auto-tuning AT: In basal display status, Press  and hold for 2 seconds, the At parameter will appear, press  to change the OFF of the lower display window to on, and then press  to confirm to start the self-tuning function. The lower display of the instrument will flash and display the word "At", and the instrument can automatically calculate the PID parameters after 2 oscillation cycles of ON-OFF control. If the auto-tuning is determined to be given up in advance, press  again and hold it for about 2 seconds to call up the At parameter, and set on to OFF, and then press  to confirm. If the instrument is running, auto-tune will cause the program timing to be paused to ensure that the given value does not change. In the system with heating/cooling bidirectional output, it is necessary to separate two groups of tuning PID parameters. When the instrument control is in the AUX cold output, start At, and then automatically tune the cold output parameters such as P2, I2, and d2.

Note 1: AiFUZZY artificial intelligence fuzzy logic PID adjustment algorithm combines fuzzy control (FUZZY) and proportional integral derivative (PID) control. It has strong adaptability, good control effect, simple and easy to use, strong robustness, and can maintain stable control performance in uncertain and complex environments. When the instrument chooses AiFUZZY adjustment mode and is used for the first time, the self-tuning function can be activated to assist in determining PID and other control parameters.

Note 2: The parameter values obtained by the system tuning under different given values are not exactly the same. Before executing the auto-tuning function, the given value SV should be set to the most commonly used value or the middle value, if the system is an electric furnace with good heat preservation performance, the given value SV should be set at the maximum value used by the system, and it is forbidden to modify the SV value during the self-tuning process. Depending on the system, the time required for auto-tuning can vary from seconds to hours.

Note 3: The control hysteresis parameter HYS also affects the auto-tuning results. Generally, the smaller the setting value of HYS, the higher the accuracy of the auto-tuning parameters. However, if the HYS value is too small, it may cause the misoperation of the bit adjustment due to the input fluctuation, which may set completely wrong parameters. HYS=2.0 is recommended.

Note 4: The control effect may not be the best at the end of self-tuning. Due to the self-learning function, the best effect can be obtained after a period of use.

■ 9. Parameter table and functions

9.1 Field parameter

In the basic display state, press and hold ← key 2 seconds, Enter the field parameters.

Code	Name	Description	Range
<i>StEP</i> (StEP)	Current execution Program segment (applicable only to 879)	Indicating the currently executing program segment number. Modify this parameter, the program will immediately jump, for example: the current StEP=3, represent the program The runs to the third segment. If you set StEP=8, the program immediately jumps to the eighth segment execution. The settings range for StEP is limited by PrGd and PrG, example:PrGd=8, PrG=2, and so on The program is divided into 8 curves. Now the program performs second curves,Now the program executes the 2 curve, executed by the 11-20 segment program, and the StEP set range is limited to 11-20, and After the instrument is stopped running (StoP), the StEP is automatically set to initial segment 11. Another example: PrGd=0, PrG=0, PrSn=80, then the program does not group, then StEP settings range 1-80, and After the instrument is stopped running (StoP), the StEP is automatically set to initial segment 1.	1~80 (Ex-factory Value 1)
<i>PrG</i> (PrG)	Curve group number (applicable only to 879)	Display the currently executing curve group number. When Prgd set curve grouping, you can program multiple curves to deal with different technology to be Seeking, by choosing this parameter to choose to perform the appropriate curve. The PrG setting range is limited by the PrGd parameter: When PrGd = 0, the program is not grouped, PrG can not be set, PrG is fixed at 0. When PrGd = 4, the program is forcibly divided into 4 groups of curves, PrG setting range is 1-4. When PrGd = 8, the program is forcibly divided into 8 groups of curves, PrG setting range is 1-8. When PrGd is forced to group, you can pre program a number of different groups of curves, Then by setting PrG you can quickly and easily choose to execute the appropriate curve. For example: PrGd = 4, PrG = 2, then the program is forced into four groups of curves, the current implementation of the second curve (ie, to implement the procedures in paragraphs 21-40),When the controller implement stop after, StEP is automatically set as the start of the 2nd curve (ie, 21 steps)	0~8 (Ex-factory Value 0)
random	Section setting time and already run time(applicable only to 879)	The PV display segment sets the time, and the SV displays the already running time. For example, if the current PV display 30.0/SV shows 10.0, it means that the current running segment setting time is 30.0 minute, and the already running time is 10.0 minute.	
<i>Pi dn</i>	PID parameter group number (applicable only to 879)	Displays the currently running PID parameter group number. This parameter is programmatically defined. 1: specifies the use of Group 1 PID parameters. 2: specify the use of Group 2 PID parameters. 3: specify the use of Group 3 PID parameters.	0~3 (Ex-factory Value 1)

	Custom field parameters	Most to 8 field parameters can be defined by FP1 ~ FP8 (The defined parameters will be transferred from the function parameters or control parameters to the field parameter)	
LoL	Password lock	Set the LoL=800 and then press the (F/←) key to enter the function parameters. Set the LoL=801 and then press the (F/←) key to enter the control parameters. If LoL≠800 or 801, press (F/←) the key to return the basic display state.	0~9999 (Ex-factory Value 0)

9.2 Function parameter

In the field parameters, set Loc=800, Then press the (F/←) key to enter the function parameters.

Code	Name	Description	Range
HiAL	High limit alarm	Alarm on when PV>HIAL Alarm off when PV<HIAL-AHYS, When the value set to Max. will disable this function Alarm output action can be defined by parameter ALtd.	-999~3200 [-9990~3200]
LoAL	Low limit alarm	Alarm on when PV<LoAL; Alarm off when PV>LoAL+AHYS When the value set to Min. will disable this function	(HiAL Ex-factory Value 3200) (LoAL Ex-factory Value -999)
HdAL	Deviation high alarm	Alarm on when PV-SV>HdAL; Alarm off when PV-SV<HdAL-AHYS When the value set to Max. will disable this function	(HdAL Ex-factory Value 3200)
LdAL	Deviation low alarm	Alarm on when PV-SV<LdAL; Alarm off when PV-SV>LdAL+AHYS When the value set to Min. will disable this function HdAL and LdAL can also be used as high limit and low limit alarms when needed.(Refer to the description of parameter SSCo)	-999~3200 [-9990~3200] (Ex-factory Value -999)
LbA	Control loop break off / shorted Alarm	When the instrument control output is equal to otL or otH, and the continuous time is greater than LBA setting time, And the PV measurement does not exceed 2 °C change, then determine the control loop failure, the output alarm. The time unit of LBA is second and the alarm port output is defined by ALtd.When LBA = 0, cancel the LBA Alarm function.	0~9999 sec (Ex-factory Value 0)
ALtd (ALtd)	Alarm output definition	The number of bits of ALtd represents the output port, ones bits represents AL1, tens bits represents AL2, hundreds bits represents AUX, The value of each bit 0 ~ 9 represents the different alarm function selection, 0 represents no alarm output, 1, 2, 3, 4, 5, 6, 7, 8, 9 respectively represents to HIAL, LoAL, HdAL, LdAL, HIAL+LoAL (Outside the area) , HdAL+LdAL (Outside the area), HIAL+LoAL (within the area) , HdAL+LdAL (within the area), LBA.	0~9999 (Ex-factory Value 1)

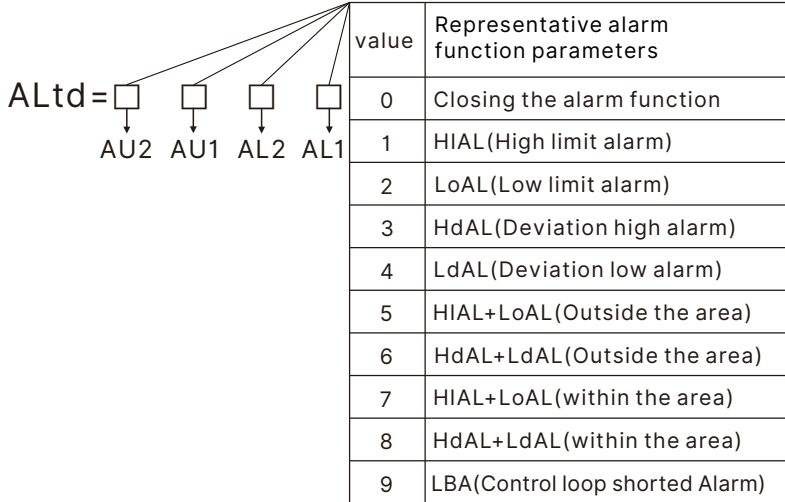
		 <table border="1" data-bbox="855 230 1295 730"> <thead> <tr> <th>value</th> <th>Representative alarm function parameters</th> </tr> </thead> <tbody> <tr><td>0</td><td>Closing the alarm function</td></tr> <tr><td>1</td><td>HIAL (High limit alarm)</td></tr> <tr><td>2</td><td>LoAL (Low limit alarm)</td></tr> <tr><td>3</td><td>HdAL (Deviation high alarm)</td></tr> <tr><td>4</td><td>LdAL (Deviation low alarm)</td></tr> <tr><td>5</td><td>HIAL+LoAL (Outside the area)</td></tr> <tr><td>6</td><td>HdAL+LdAL (Outside the area)</td></tr> <tr><td>7</td><td>HIAL+LoAL (within the area)</td></tr> <tr><td>8</td><td>HdAL+LdAL (within the area)</td></tr> <tr><td>9</td><td>LBA (Control loop shorted Alarm)</td></tr> </tbody> </table> <p>For example: Altd = 961, which means that the HIAL upper limit alarm is output by AL1 port, HdAL and LdAL are output by AL2 port can realize outside the area deviation alarm, LBA is output by AU1 port, AU2 port no alarm output.</p>	value	Representative alarm function parameters	0	Closing the alarm function	1	HIAL (High limit alarm)	2	LoAL (Low limit alarm)	3	HdAL (Deviation high alarm)	4	LdAL (Deviation low alarm)	5	HIAL+LoAL (Outside the area)	6	HdAL+LdAL (Outside the area)	7	HIAL+LoAL (within the area)	8	HdAL+LdAL (within the area)	9	LBA (Control loop shorted Alarm)	
value	Representative alarm function parameters																								
0	Closing the alarm function																								
1	HIAL (High limit alarm)																								
2	LoAL (Low limit alarm)																								
3	HdAL (Deviation high alarm)																								
4	LdAL (Deviation low alarm)																								
5	HIAL+LoAL (Outside the area)																								
6	HdAL+LdAL (Outside the area)																								
7	HIAL+LoAL (within the area)																								
8	HdAL+LdAL (within the area)																								
9	LBA (Control loop shorted Alarm)																								
<i>RHYS</i>	Alarm hysteresis	Avoid frequent alarm on-off action because of the fluctuation of PV.	0~200.0 [0-2000] (Ex-factory Value 2)																						
<i>Rdon</i>	Alarm ON delay	Alarm ON action delay, unit is seconds, When Adon=0, will no alarm ON delay function.	0~999 (Ex-factory Value 0)																						
<i>RdoF</i>	Alarm OFF delay	Alarm OFF action delay, unit is seconds, When AdoF=0, will no alarm OFF delay function.																							
<i>Rdt</i> (Adt)	Alarm delay definition	0: no alarm delay function. 1:AL1 alarm output has delay. 2:AL2 alarm output has delay. 3:AUX alarm output has delay. 5:AL1, AL2 alarm output has delay. 7:AL1, AL2, AUX alarm output has delay. 4 and 6:empty.	0~7 (Ex-factory Value 0)																						
<i>RL L</i>	Definition of alarm self lock	When the alarm self-locking takes effect, the alarm output remains self - locking, no matter how the measured value changes. When the measured value does not conform to the alarm condition, the power supply is reopened, and the alarm will be lifted. 0: no alarm self locking function. 1:AL1 alarm has self lock. 2:AL2 alarm has self lock. 3:AUX alarm has self lock. 5:AL1, AL2 alarm has self lock. 7:AL1, AL2, AUXalarm has self lock. 4 and 6:empty.	0~7 (Ex-factory Value 0)																						

<i>RLE</i>	Definition of First alarm exemptions	When Power start, if the happen first alarm will be exemption. 0: No First alarm exemptions function. 1: HIAL has First alarm exemptions. 2: LoAL has First alarm exemptions. 3: HdAL has First alarm exemptions. 4: LdAL has First alarm exemptions. 5: HIAL, LoAL has First alarm exemptions. 6: HdAL, LdAL has First alarm exemptions. 7: HIAL, LoAL, HdAL, LdAL has First alarm exemptions.	0~7 (Ex-factory Value 0)																																																																				
<i>InL</i> (Int)	Input specification Code	<p>AiFUZZY-819/879 has a variety of input specifications to choose from and can be set freely, as follows:</p> <table border="1"> <thead> <tr> <th>Int</th> <th>Input spec</th> <th>Int</th> <th>Input spec</th> </tr> </thead> <tbody> <tr> <td>0</td> <td>K(-50.0~+1300°C)</td> <td>18</td> <td>J(0~300.00°C)</td> </tr> <tr> <td>1</td> <td>S(-50~+1700°C)</td> <td>20</td> <td>Cu50</td> </tr> <tr> <td>2</td> <td>R(-50~+1700°C)</td> <td rowspan="2">21</td> <td rowspan="2">Pt100(-200.0~+600.0°C)</td> </tr> <tr> <td>3</td> <td>T(-200~+350°C)</td> </tr> <tr> <td>4</td> <td>E(0~800°C)</td> <td rowspan="2">22</td> <td rowspan="2">Pt100(-100~+300.00°C)</td> </tr> <tr> <td>5</td> <td>J(0~1000°C)</td> </tr> <tr> <td>6</td> <td>B(200~1800°C)</td> <td>25</td> <td>0~75mV</td> </tr> <tr> <td>7</td> <td>N(0~1300°C)</td> <td>26</td> <td>0~80Ω</td> </tr> <tr> <td>8</td> <td>WRe3-WRe25</td> <td>27</td> <td>0~400Ω</td> </tr> <tr> <td>9</td> <td>WRe5-WRe26</td> <td>28</td> <td>0~20mV</td> </tr> <tr> <td rowspan="2">10</td> <td rowspan="2">Special custom input specification</td> <td>29</td> <td>0~100mV</td> </tr> <tr> <td>30</td> <td>0~60mV</td> </tr> <tr> <td rowspan="2">12</td> <td rowspan="2">F2 radiation type pyromter</td> <td>31</td> <td>0~1V</td> </tr> <tr> <td>32</td> <td>0.2~1V</td> </tr> <tr> <td rowspan="2">15</td> <td rowspan="2">Spare</td> <td>33</td> <td>1~5V(4~20mA)</td> </tr> <tr> <td>34</td> <td>0~5V(0~20mA)</td> </tr> <tr> <td rowspan="2">16</td> <td rowspan="2">Spare</td> <td>35</td> <td>-20~+20mV</td> </tr> <tr> <td>36</td> <td>-100~+100mV</td> </tr> <tr> <td>17</td> <td>K(0~300.00°C)</td> <td>37</td> <td>-5V~+5V</td> </tr> </tbody> </table>	Int	Input spec	Int	Input spec	0	K(-50.0~+1300°C)	18	J(0~300.00°C)	1	S(-50~+1700°C)	20	Cu50	2	R(-50~+1700°C)	21	Pt100(-200.0~+600.0°C)	3	T(-200~+350°C)	4	E(0~800°C)	22	Pt100(-100~+300.00°C)	5	J(0~1000°C)	6	B(200~1800°C)	25	0~75mV	7	N(0~1300°C)	26	0~80Ω	8	WRe3-WRe25	27	0~400Ω	9	WRe5-WRe26	28	0~20mV	10	Special custom input specification	29	0~100mV	30	0~60mV	12	F2 radiation type pyromter	31	0~1V	32	0.2~1V	15	Spare	33	1~5V(4~20mA)	34	0~5V(0~20mA)	16	Spare	35	-20~+20mV	36	-100~+100mV	17	K(0~300.00°C)	37	-5V~+5V	0~37 (Ex-factory Value 0)
Int	Input spec	Int	Input spec																																																																				
0	K(-50.0~+1300°C)	18	J(0~300.00°C)																																																																				
1	S(-50~+1700°C)	20	Cu50																																																																				
2	R(-50~+1700°C)	21	Pt100(-200.0~+600.0°C)																																																																				
3	T(-200~+350°C)																																																																						
4	E(0~800°C)	22	Pt100(-100~+300.00°C)																																																																				
5	J(0~1000°C)																																																																						
6	B(200~1800°C)	25	0~75mV																																																																				
7	N(0~1300°C)	26	0~80Ω																																																																				
8	WRe3-WRe25	27	0~400Ω																																																																				
9	WRe5-WRe26	28	0~20mV																																																																				
10	Special custom input specification	29	0~100mV																																																																				
		30	0~60mV																																																																				
12	F2 radiation type pyromter	31	0~1V																																																																				
		32	0.2~1V																																																																				
15	Spare	33	1~5V(4~20mA)																																																																				
		34	0~5V(0~20mA)																																																																				
16	Spare	35	-20~+20mV																																																																				
		36	-100~+100mV																																																																				
17	K(0~300.00°C)	37	-5V~+5V																																																																				
<i>dP</i>	Display Resolution	Four formats (0/0.0/0.00/0.000) are selectable. Note 1: For thermocouples or RTD input, only 0 or 0.0 is selectable, and the internal resolution is 0.1. When S type thermocouple is used, dP is recommended to be 0. If Inp= 17,18 or 22, resolution will support display 0.0 or 0.00	(Ex-factory Value 0)																																																																				
<i>InL</i>	Signal scale low limit	Used to define the lower limit scale value of the linear input signal(Display lower limit value); it is also used to define the lower limit scale of the output signal when the controller is used as a transmission output(CntL=Pvtr or Svtr) .	999~3200 [-9990~32000] (Ex-factory Value 300)																																																																				
<i>InH</i>	Signal scale high limit	Used to define the high limit scale value of the linear input signal(Display high limit value); it is also used to define the high limit scale of the output signal when the controller is used as a transmission output(CntL=Pvtr or Svtr) .	999~3200 [-9990~32000] (Ex-factory Value 300)																																																																				

<i>Sc</i>	Input Shift Adjustment	Sc is used to shift input to compensate the error caused by transducer, input signal, or auto cold junction compensation of thermocouple. PV after compensation=PV before compensation + Sc It is generally set to 0. The incorrect setting will cause measurement inaccurate.	-199~400 [-1990~4000] (Ex-factory Value 0)
<i>InF</i>	PV input filter	The value of InF will determine the ability of filtering noise. When a large value is set, the measurement input is stabilized but the response speed is slow. Generally, it can be set to 1 to 3. If great interference exists, then you can increase parameter "InF" gradually to make momentary fluctuation of measured value less than 2 to 5. When the instrument is being metrological verified, "InF" s can be set to 0 or 1 to shorten the response time.	0~40 (Ex-factory Value 0)
<i>du</i>	Temperature unit	°C: Celsius. °F: Fahrenheit. Thermocouples and RTDs only	(Ex-factory Value °C)
<i>rSPL</i> (rSPL)	Signal scale low limit for External input SV set value	Use the external signal remote control SV set value function to define the lower limit of the signal scale. Use the position proportional output function to define the lower limit of the valve position feedback signal, This parameter can be set automatically by the valve auto-tuning function.	-999~3200 (-9990~32000)
<i>rSPH</i>	Signal scale high limit for External input SV set value	Use the external signal remote control SV set value function to define the high limit of the signal scale. Use the position proportional output function to define the high limit of the valve position feedback signal, This parameter can be set automatically by the valve auto-tuning function. WARNING: Valve position auto-tuning values Do not modify rSPH and rSPL parameters unless you are a professional.	
<i>AdrS</i> (AdrS)	Communication address	If the instrument's COMM port is configured with the S-type RS485 or RS232C communication interface module, it can be connected with the computer to realize multi-computer connection. For computers without an RS485 interface, you can add an RS232C/RS485 converter or a USB/RS485 converter. The AdrS parameter is used to define the instrument communication address, the valid range is 0 ~ 80. The instruments on the same communication line should be set a different AdrS value to distinguish each other.	0~100 (Ex-factory Value 1)
<i>bPS</i>	Baud rate	bPS parameter defines the communication baud rate, which can be defined as the range of 1200 ~ 19200bit / s (1.2K~19.2K).	0~19.2K (Ex-factory Value 9600)
<i>PRr1</i>	Communication verification	nonE: No verification. odd: Odd number verification. EVEN : Even number verification.	(Ex-factory Value nonE)

Ɔoññ	Communication protocol	FBUS: instrument communication protocol for FTBUS. MBUS: instrument communication protocol for MODBUS.	(Ex-factory Value MBUS)
Ɛut (Evt)	Event input type	When I2 module was installed, the meter have following functions. nonE : Disable event input function. reSt : Run / Stop switching function. Connected in short time, start to running program, keep connect more than 2 sec, program switch to stop. SP1.2 : Switching between setpoint 1 and setpoint 2 when use 919 or PrSn=0 at 979. MIO in open status, SV=SP1, when MIO in close status, SV=SP2. Pid2 : Switching 1st PID and 2nd PID. When use as single direction control, MIO in open status, P, I, d and CP was active, when MIO in close status, P2, I2, d2 and CP2 was active.	(Ex-factory Value oFF)
55Ɔo	Advanced System Code	SSCo is used to select advanced function. SSCo is used to select advanced function. The value of AF is calculated as below: $AF=A \times 1+B \times 2+C \times 4+D \times 8+E \times 16+F \times 32+G \times 64+H \times 128$ A=0, HIAL and LoAL work as high and low limit alarms; A=1, HIAL and LoAL will become to deviation high alarm and Deviation low alarm, and the instrument can have two groups of deviation high and low limit alarms. B=0, HdAL and LdAL work as deviation high and low limit alarms; B=1, HdAL and LdAL work as high and low limit alarms, and the instrument can have two groups of high and low limit alarms. C=0, Alarm and control hysteresis work as unilateral hysteresis; C=1, As bilateral hysteresis. D=0, The SV set value is set by the instrument panel operation; D=1, The SV set value is external signal remote control and the external signal is from the 5V input. E=0, The external input SV set value signal is 1-5V; E=1, The external input SV set value signal is 0-5V. F=0, The transmit output is defined scale with lnL/lnH; F=1, The transmit output is defined scale with rSPL/rSPH. G = 0, normal input mode, G = 1, linear input signal for rooting processing. H=0, Fine control mode, internal control resolution was demonstration's 10 times. When on linear input mode, biggest display value is 3200 units; H=1, Wide range display mode, This mode is selected when the linear input requires a maximum display value greater than 3200.	0~255 (Ex-factory Value 0)
SPL	Low limit of SV	Minimum value that SV is allowed to be.	-999~3200 [-9990~32000]
SPH	Upper limit of SV	Maximum value that SV is allowed to be.	(Ex-factory Value 0)
SP1	Given point 1	For 819meter or 879 parameters PrSn=0 or 1, normally Given value SV=SP1.	999~3200

<i>SP2</i>	Given point 2	For 819 or 879 parameters PrSn=0 or 1, When I2 module installed in MIO position, SP1 and SP2 can be switched by an external switch. If the switch is off, SV=SP1; if the switch is on, SV=SP2.	-999~3200 [-9990~32000] (Ex-factory Value 0)
<i>Pont</i>	Program run mode after power restart (applicable only to 879)	Cont : Continue to run the program from the original break point. If STOP STATUS was activated before power cut, then it (the program) will keep stop status after power restart. StoP : Stop the program after power restart run1 : Start to run the program from starting segment unless the instrument was in "stop" state before power cut. dASt : If these have deviation alarm after power resume, then stop the program, otherwise, continue run the program from the original break point. HoLd : Go into HOLD state after power on. If it is in StoP state before power cut, then keep in StoP State after power on.	(Ex-factory Value run1)
<i>PSYS</i>	Program Running mode (applicable only to 879)	The PSYS parameter is used to select the program control function, which is calculated as follows: $PSYS = A \times 1 + B \times 2 + C \times 4 + D \times 8 + E \times 16 + F \times 32$ When A=0, Disenable ready (rdy) function; A=1, Enable ready (rdy) function. B=0, Ramp mode; B=1, Soak mode. C=0, Time unit in Minute, the range is 0.1~3200; C=1, Time unit in Hour, the range is 0.1~3200. D=0, Disable PV start up function; D=1, Enable PV start up function. E=0, When work as program generator, upper windows display PV;E=1, When work as program generator, upper windows display the current step. F = 0, the standard operating mode; F = 1, the program running RUN operation will enter the pause(HOLD) state.	(Ex-factory Value 0)
<i>PrGd</i> (PrGd)	Program grouping definition (applicable only to 879)	When PrGd=0, no grouping. When the PrGd=4 is divided into 4 curves, each group has 20 segments program , SP1-20 segment procedures for the 1 curve group, SP21-40 segment procedures for the 2 curve group, SP41-60 segment procedures for the 3 curve group, SP61-80 segment procedures for the 4 curve group. When the PrGd=8 is divided into 8 curves, each group has 10 segments program. SP1-10 segment procedures for the 1 curve group, SP11-20 segment procedures for the 2 curve group, SP21-30 segment procedures for the 3 curve group, SP31-40 segment procedures for the 4 curve group, SP41-50 segment procedures for the 5 curve group, SP51-60 segment procedures for the 6 curve group, SP61-70 segment procedures for the 7 curve group, SP71-80 segment procedures for the 8 curve group.	0~8 (Ex-factory Value 0)

<i>PrSn</i> (PrSn)	No. of Program step (applicable only to 879)	When Prgd=0, PrSn to define the number of program in use. PrSn= 0: disable the program running mode, then 879 will same as 819, meanwhile, can set the parameter "rAte" to limit the ramp time. Pno=1~80: 879 working as normal programmable controller. When Prgd=4 or 8, the PrSn is fixed to 80.	0~8 (Ex-factory Value 80)																																								
<i>LoC2</i>	Parameter Lock	Parameter was protected by LoC2 (Parameter LOCK) to prevent setting error. The function was shown as below: √ : allow to modify data or execute X : not allow to modify data or execute Run, Stop, Hold. and Program Time & Temp. Function just for 879 only	Ex-factory Value oFF																																								
		<table border="1"> <thead> <tr> <th>LOC</th> <th>Field parameters</th> <th>SV</th> <th>Program Step Time & Temp</th> <th>Shortcut keys for run, stop, or hold</th> </tr> </thead> <tbody> <tr> <td>oFF</td> <td>√</td> <td>√</td> <td>√</td> <td>√</td> </tr> <tr> <td>LCK1</td> <td>√</td> <td>√</td> <td>√</td> <td>×</td> </tr> <tr> <td>LCK2</td> <td>√</td> <td>×</td> <td>×</td> <td>√</td> </tr> <tr> <td>LCK3</td> <td>√</td> <td>×</td> <td>×</td> <td>×</td> </tr> <tr> <td>LCK4</td> <td>×</td> <td>√</td> <td>√</td> <td>√</td> </tr> <tr> <td>LCK5</td> <td>×</td> <td>√</td> <td>√</td> <td>×</td> </tr> <tr> <td>LCK6</td> <td>×</td> <td>×</td> <td>×</td> <td>×</td> </tr> </tbody> </table>	LOC	Field parameters	SV	Program Step Time & Temp	Shortcut keys for run, stop, or hold	oFF	√	√	√	√	LCK1	√	√	√	×	LCK2	√	×	×	√	LCK3	√	×	×	×	LCK4	×	√	√	√	LCK5	×	√	√	×	LCK6	×	×	×	×	
LOC	Field parameters	SV	Program Step Time & Temp	Shortcut keys for run, stop, or hold																																							
oFF	√	√	√	√																																							
LCK1	√	√	√	×																																							
LCK2	√	×	×	√																																							
LCK3	√	×	×	×																																							
LCK4	×	√	√	√																																							
LCK5	×	√	√	×																																							
LCK6	×	×	×	×																																							
<i>FP1</i> <i>FPB</i>	Field parameter definition	You can select 8 parameters in the function parameters or control parameters as field parameters. If there are no or less than 8 field parameters, the FP* value can be set to nonE.	Ex-factory Value nonE																																								

9.3 Control parameter

In the field parameters, set Loc=801, Then press the $\text{F1} \leftarrow$ key to enter the control parameters.

Code	Name	Description	Range
<i>EntL</i> (CntL)	Control mode	onoF: on-off control. For situation not requiring high precision. FPId: advanced artificial intelligence FUZZY+PID control(Recommended use). Pvtr: The controller is used as a measurement display or digital display transmitter. the SV will display the temperature unit. when the linear signal is input, the SV will not be displayed, and can directly use the PV value as the output value. when the OUT is installed with a 4-20 mA module, the meter can be used as a transmitter. Svtr: Directly use the SV value as the output value. When OUT installs the 4-20mA module, the meter can be used as the program given generator.	(Ex-factory Value FPId)
<i>HYS</i>	Control Hysteresis	HYS is used for on-off control to avoid frequent on-off action of relay. For a reverse acting (heating) system, when PV > SV, output turns off; when PV < SV - HYS, output turns on.	0~200.0 [0-2000]

		For a direct acting (cooling) system, when PV<SV, output turns off; when PV>SV+HYS, output turns on.	(Ex-factory Value 2)
orEv (orEv)	Acting method (Control direction)	onr: Reverse acting. Increase in measured variable causes a decrease in the output, such as heating control. ond: Direct acting. Increase in measured variable causes an increase in the output, such as refrigerating control.	(Ex-factory Value onr)
dEz (dEz)	dead zone	dEz is only suitable for heating-cooling two-way adjustment. The dead zone is set around the SV set point. When the set value is positive, it becomes a static zone (no action zone). When the set value is negative, it becomes an overshoot zone. The decimal point position is defined by the dP parameter.	-1999~9999 (Ex-factory Value 0)
Srun (Srun)	Running Status	Run: Runs the control state and allows the run or stop operation from the panel keys. StoP: Stops the state and allows the run or stop operation from the panel keys. HoLd: When the controller is 819 or 879 and the PrSn=0, this state is the same as the running state, but it is prohibited to perform the run or stop operation from the panel keys. When the controller is 879 and the parameter PrSn>0 program control, the meter keeps constant temperature controlling output in this state, but pauses the timing, and the second display SV flashes to display "HoLd", which can be run or stop by the panel keys operation to release the hold. Note: You cannot enter the HOLD state by using the panel keys operation. You can enter this state only by directly modifying this parameter.	Ex-factory Value run
A-M (A-M)	Auto / manual Control selection	OFF: no automatic / manual switching control function, the instrument for the automatic control of the state. Man: manually control the state, manually adjust the output of oUT, and can switch to automatic control.. Auto: automatic control state, oUT output determined by the CntL decision after the decision, and can switch to manual control. FMAn: fixed manual control state, this mode prohibits the direct operation from the front panel keys Change to automatic state.	Ex-factory Value OFF
At (At)	Auto tuning	oFF: Auto tuning function was off. on: Start the PID parameter auto-tuning function, and the auto-tuning finish will automatically return to oFF. FoFF: Auto tuning function was off, and cannot activate again by pressing key from panel .	Ex-factory Value oFF
P	Proportional band (No.1 PID parameter)	Proportional band in FPID control. Instead of percentage of the measurement range, the unit is the same as PV. Generally, optimal P, I, D and CP can obtained by auto tuning. They can also be manually inputted if you already know the correct values.	1~3200 [32000] (Ex-factory Value 25)
I	Integral Time (No.1 PID parameter)	Integration time in FPID control, the unit is second, and the integral action is canceled when I=0.	1~9999 sec

			(Ex-factory Value 200)
d	Differential time (No.1 PID parameter)	Differential time in FPID control, the unit is 0.1 seconds, and the differential action is cancelled when $d=0$.	0~3200 sec (Ex-factory Value 50)
CP	Control cycle (No.1 PID parameter)	<p>Small value can improve control accuracy. For SSR, thyristor or linear current output, it is generally 0.5 to 3 seconds (Ex-factory set value 2 sec).</p> <p>For Relay output or in a heating/cooling dual output control system, generally 15 to 40 seconds (Ex-factory set value 15 sec), because small value will cause the frequent on-off action of mechanical switch or frequent heating/cooling switch, and shorten its service life. It is recommended that CP be set to about 1/5-1/10 of differential time (basically equal to the lag time of the system).</p> <p>When the parameter OUt or Aut = rELy, CP will be limited to more than 3 seconds. Auto tuning will automatically set CP to suitable value considering both control precision and mechanical switch longevity.</p> <p>When the parameter CntL = onof, CP will be used as timer to make delay time to avoid the power restart in short period. It is suitable for compressor protection.</p> <p>If the output for the control valve, recommended CP=3~15 seconds, taking into account the response speed and avoid the valve frequent action.</p>	0.2~300.0 (Ex-factory value 2, OUT for relay, electrical output, when the factory value is: 15)
$P2$	Proportional band 2 (No.2 PID parameter)	When the instrument uses the heating / cooling dual output adjustment, it is used as a cold output proportional band. When 879 can be used as the second group of PID proportional band.	1~3200 [32000] (Ex-factory Value 25)
$I2$	Integral Time 2 (No.2 PID parameter)	When the instrument uses the heating / cooling dual output adjustment, it is used as a cold output time of integral. When 879 can be used as the second group of PID time of integral.	1~9999 sec (Ex-factory Value 200)
$d2$	Differential time 2 (No.2 PID parameter)	When the instrument uses the heating / cooling dual output adjustment, it is used as a cold output time of differential. When 879 can be used as the second group of PID time of differential.	0~3200 (Ex-factory Value 50)
$CP2$	Control cycle 2 (No.2 PID parameter)	When the instrument uses the heating / cooling dual output adjustment, it is used as a cold output control period. When 879 can be used as the second group of PID control period.	0.2~300.0 (Ex-factory Value 2)

<i>P3</i>	Proportional band 3 (No.3 PID parameter)	Applicable only to 879	1~3200 [32000] (Ex-factory Value 25)
<i>I3</i>	Integral Time 3 (No.3 PID parameter)	Applicable only to 879	1~9999 sec (Ex-factory Value 200)
<i>D3</i>	Differential time 3 (No.3 PID parameter)	Applicable only to 879	0~3200 sec (Ex-factory Value 50)
<i>[P3]</i>	Control cycle 3 (No.3 PID parameter)	Applicable only to 879	0.2~300.0 (Ex-factory Value 2)
<i>oUt</i> (oUt)	OUT main output type	Ssr: SSr drive voltage output or TRIAC no contact normally output or thyristor zero crossing trigger signal. rELy: Relay contact output 0-20: 0~20mA linear current output(Also suitable for 0-5V or 0-10V output). 4-20: 4~20mA linear current output(Also suitable for 1-5V or 2-10V output). PHA: Single-phase phase-shift output. PHA is only for 50Hz power supply, and don't support bidirectional control system. NFEd: no feedback signal position proportional output, direct control valve motor positive / reverse, Valve travel time defined by Vrtt parameters. Fed: position feedback signal output, the valve travel time should be more than 10 seconds, Feedback signal input from the 0~5V/1~5V input. Note: The External input SV set value function can no longer be used in this output mode. FEAt: auto-tuning valve position, the instrument will first close the valve will be feedback signal recorded in the rSPL parameters, and then fully open the valve memory valve feedback signal in the rSPH parameters, after completion Automatically returns the FEd control mode.	(Ex-factory value according to purchase, model set)
<i>RUt</i> (Aut)	AUX auxiliary output type (as a refrigeration output)	Ssr: SSr drive voltage output. rELy: Relay contact output. 0-20: 0~20mA linear current output(Also suitable for 0-5V or 0-10V output). 4-20: 4~20mA linear current output(Also suitable for 1-5V or 2-10V output).	(Ex-factory value according to purchase, model set)
<i>oL</i> (oL)	Output low limit	0~100%: oL is the minimum output of OUT in single directional control system. -1~-110%: The instrument works for a bidirectional system,	-110~+110%

		and has heating/refrigerating dual output. OUT (main output) works for heating, and AUX (Auxiliary output) works for refrigerating. In a bidirectional system, otL for define the limitation of maximum cooling output. So, when the otL= -100%, means no limitation on cooling output. If set otL=-110%, it can made current output excess 10% on maximum output. When the output type is SSR output or relay output, maximum of cooling output should not set more than 100%	(Ex-factory Value 0)
otH (otH)	Output upper limit	limit the maximum output value of the main output oUt, the setting range is 0~110%. When SSR or relay output, the maximum output limit should not be greater than 100%. 110% can make the current output such as (4~20mA) the maximum range exceeds 100%. Suitable for special occasions. When the measured value PV is less than otEr, otH limits the maximum output value of the main output(oUt), and when PV is greater than otEr, the system correction output upper limit is 100%;In the non-feedback position proportional output (when oUt = nFed), if otH is less than 100, the Controller Auto Tuning the valve position at power-on. If otH = 100, the Controller Auto Tuning the valve position when the output is 0% and 100% , Can shorten the power on time. otH setting must be greater than otL.	0~110% (Ex-factory Value 100)
VrTt (VrTt)	Valve travel time	Defines the travel time of the valve rotation when the meter is the position proportional control output,If there is a valve feedback signal, the instrument will automatically select the valve control signal according to VrTt's setting. Of the hysteresis, the shorter the travel time, the greater the hysteresis, the valve positioning accuracy will be reduced. When using a valveless feedback signal mode or valve feedback signal to generate an overrange malfunction,The instrument will be based on VrTt travel time comparison output to determine the valve motor action time.	10~300
otEr (otEr)	Work range of OPH	otEr can implement the segmentation output power limit. When PV<otEr, the upper limit of OUP is OPH; when PV>otEr, the upper limit of OUP is 100%. For example, to avoid that the temperature raises too quickly, under 150°C, a heater can work only under 30% of output power, then we can set otEr=150.0 (°C), OtH=30 (%), then, when the temperature is lower than 150 °C, the upper limit of the output power is 30%, 150°C or more, and the upper limit of the output power is 100%.	0-3200°C /mi-999~3200°C or Linear unitn (Ex-factory Value 3200)
rAtE (rAtE)	Heating rate limit	If rAtE is set to valid, when the program starts, if PV < SV, the temperature will first rise to the first set value according to the heating rate limit defined by rAtE. In the temperature increase rate limit state, "PV" character flashes. For slope mode, rAtE is only valid for the first paragraph program, while in platform mode, rAtE is valid for any paragraph program.	0-3200°C /min (Ex-factory Value 0)

10. Additional Remarks of Special Functions

10.1 Position proportional output

AiFUZZY-819/879 can directly drive the motor to control the valve, and supports two modes: valve position feedback signal and valve position feedback signal. When no feedback position ratio is output ($oUt=nFEd$), If otH is less than 100, the instrument will auto tuning the valve position when power on, that is, automatically close the valve when power on, and the time is valve stroke time. Meanwhile, the otH parameter can limit the maximum valve opening under the condition that the measured value PV is less than the parameter $otEr$. If the $otH = 100$ is set, the instrument will auto tuning the valve position when the output is 0% and 100%, and will not auto tuning the valve position when power on to shorten the start-up time.

When the proportional output of the feedback position is set to $oUt = FEAt$, the instrument automatically closes the valve first, then opens the valve completely, and then measures the feedback signal to set the valve position and save it. After the valve position is auto tuning, the instrument automatically sets the parameter oUt to FEd for normal control. If the feedback signal exceeds 2% of the measurement range, The instrument will decided there the feedback signal is abnormal and automatically control it in a valveless feedback mode, and display "FErr" in the lower display window to indicate an error. The feedback signal can be 1K resistor (Need to be equipped with U5 module) or 0~5V/1~5V signal (Parallel 250 resistance can be converted to 0~20mA/4~20mA).

Position proportional output (valve feedback signal is 1K resistor) wiring diagram of direct drive valve:

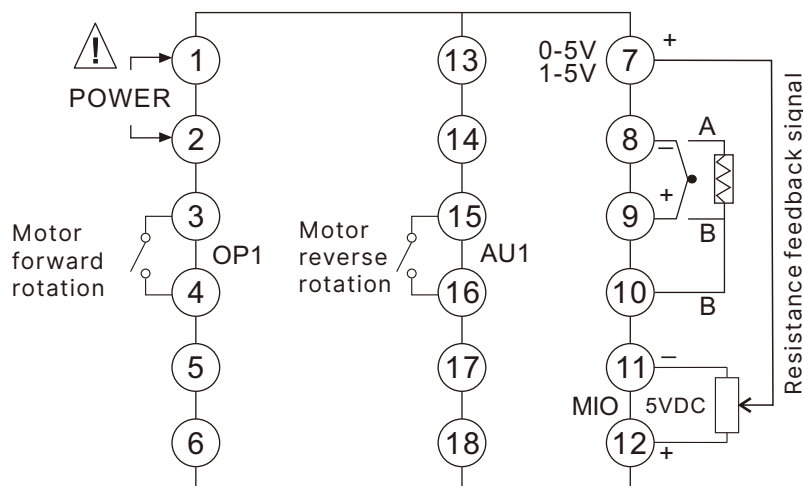

When the valve position feedback signal is a potentiometer, install a non-isolated 5V power distribution output module V5 to convert the resistance signal into a voltage signal (as the picture shows).

When the valve position feedback signal is 0-5V or 1-5V (the current signal needs to be converted into voltage by the resistor), the direct 7(+) and 8(-) terminals can be used.

10.2 Manual auto-tuning (only for valve position control and where automatic auto-tuning is not allowed)

In the system difficult to control or in the applications in which some executive bodies such as control valve is used and therefore outputs are not allowed to be greatly changed, traditional auto tuning is not suitable. AiFUZZY-819/879 instruments have manual auto tuning mode. To do this, switch the instrument to manual mode. After manual control is basically stable, start up auto tuning at manual mode, and the output will be restricted in the range between +10% and -10% of the current manual output. This function can avoid great change of valve and improve the precise of auto-tuning.

Note: before manual auto-tuning, the manual output value should be limited in the range of 10% - 90%, otherwise optimal parameters can be obtained.

10.3 Single-phase phase-shift trigger output(Power regulation output)

When OUT is set to PHA, installing a K5 or K6 module in OUT slot can single-phase phase-shift trigger a TRIAC or 2 inverse parallel SCRs. It can continuously adjust heating power by control the conduction angle of thyristor. With non-linear power adjustment according to the characters of sine wave, it can get ideal control. The trigger adopts self-synchronizing technology, so it can also work even when the power supplies of the instrument and the heater are different. Phase-shift trigger has high interference to the electric power, so user should pay attention to the anti-interference ability of other machines in the system. Now the K5 or K6 module can be only used in 50Hz power supply.

10.4 Heating/cooling dual PID dual control output

When otL is set to a negative value (-1 ~ -110%), the instrument becomes a two-way adjustment system with heating/cooling dual PID dual output functions. The OUT is used for PID heating control output, and the auxiliary output AUX is used for PID cooling control output.

as shown below:

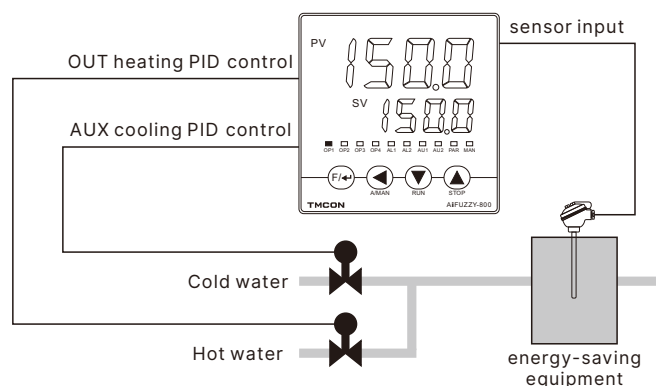

10.5 Temperature re-transmitter / Program generator / Manual current output

Besides FUZZY+PID, and on-off control, if the output is defined as current output, the instrument can also retransmit PV (process value) or SV (setpoint) into linear current and output from OUTport. The precision of current output is 0.2%FS. Base on that ability, AiFUZZY-819 can become temperature re-transmitter and AiFUZZY-879 can become program generator

The corresponding parameters are set as below:

When $CntL=Pvtr$, PV is retransmitted to linear current, the instrument works as temperature re-transmitter.

When $CntL=Svtr$, SV is transmitted and outputted, and the instrument works as manual current output controller (AiFUZZY-819) or program generator (AiFUZZY-879).

Out is used to choose output type, generally 4~20mA or 0~20mA output.

Parameter Int , InL , InH , and Sc are used for selecting input specification, setting low limit or high limit of PV and adjusting input.

For example, in order to retransmit temperature read from K thermocouple, range 0~400°C, to current 4~20mA, the parameters are set as below: $Int=0$, $InL=0.0$, $InH=400.0$, $OUT=4\sim 20$, and X linear current module is installed in OUT slot. When the temperature is less than or equal to 0°C, the output is 4mA. When the temperature equals to 400°C, the output is 20mA.

10.6 External signal remote control SV set value

When an external signal is allowed to remote control SV set value (see the $SSCo$ parameter description), the meter can input a 1-5V voltage signal from the 5V terminal of its terminal to indicate the SV value. The scale of the external signal can be determined by the $In-L/In-H$ or $rSPL/rSPH$ parameters. If the voltage signal of the external signal is less than 1V, the external signal is automatically canceled to set the SV value, and the internal set the SV value is used instead. When using the external signal remote control SV set value function, the meter measurement input cannot be used with 1-5V/0-5V, which has no effect on thermocouple, RTD and mV voltage input. If the measurement input is 0-10 mA or 4-20 mA, the main input of the meter can be set to 0-1V or 0.2V-1V, then external 100 ohm or 50 ohm resistor. The external signal remote control SV set value function can the instrument to form a ratio or cascade adjustment system to perform complex adjustment functions.

10.7 Alarm delay diagram

Schematic diagram of alarm delay output:

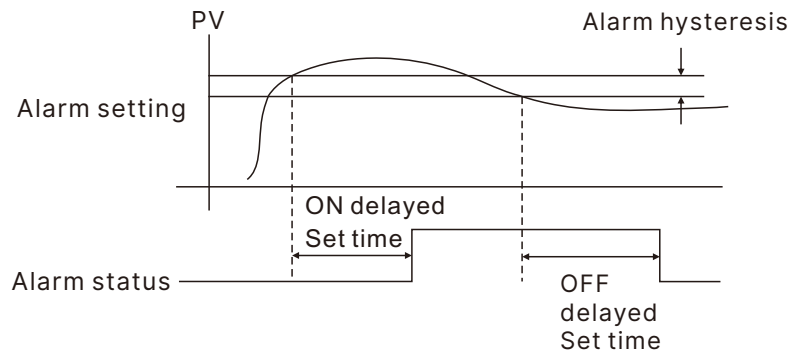

The alarm ON delay also takes effect when the power is turned on. When the interval of the alarm ON is the ON delay setting, the alarm output will not turn ON. Similarly, when the alarm OFF interval is below the OFF delay setting, the alarm output will not be turned OFF.

During the ON delay, when the alarm is turned ON → OFF → ON, the measurement is restarted from the time when the alarm is last turned ON. Similarly, during the OFF delay, when the alarm is turned OFF → ON → OFF, the measurement is restarted from the time when the alarm is finally turned OFF.

10.8 Alarm self-locking

If the alarm latch function is set to be effective, when the alarm output is ON, it hold in the ON state regardless of the temperature change.

Alarm unlock method: Release by power OFF (After the controller is powered back on, if the measured value does not meet the current alarm condition, the alarm will be OFF).

This function is usually used as an over-temperature protection function. It can be used to realize the function of forcibly turning off the main power when over-temperature occurs, until the operator releases the fault.

10.9 First alarm exemptions

Sometimes the fault alarm may occur at the beginning of power on. In a heating system, at the beginning of power on, its temperature is much lower than the set point. If low limit and deviation low limit are set and the alarm conditions are satisfied, the instrument should alarm, but there is no problem in the system. Contrarily, in a refrigerating system, the unnecessary high limit or deviation high limit alarm may occur at the beginning of power on. Therefore, Ft34** instruments offer the function of alarm blocking at the beginning of power on. When ALE is set to 1~7, the corresponding low or high alarms are blocked until the alarm condition first clears. If the alarm condition is satisfied again, the alarm will work.

10.10 LBA Control loop break off / shorted Alarm

When the control output becomes otH or otL, At each interval LBA set time as a unit to monitor of changes in the PV value, According to the amount of change to determine whether there is any abnormal control circuit. The time unit of LBA is second and by AL1 alarm.

The following conditions for the alarm status:

① When orEV is onr Reverse action: When the control output of the instrument continues to be otH, the increase of the measured value (PV) within the setting time of LBA is less than the change of LBA judgment (2°C).

When orEV is ond is positive: When the instrument control output continues to otH, the measured value (PV) decreases less than LBA judgment range (2°C) within the setting time of LBA.

② orEV is onr Inverse operation: When the instrument control output continues for otL, the measured value (PV) decreases less than the LBA judgment range (2°C) within the setting time of LBA.

When orEV is ond is in positive operation: When the instrument control output continues to otL, the measured value (PV) rises less than LBA judgment range (2°C) within the setting time of LBA.

10.11 Fine Control

Fine control means that the resolution of PID operation is 10 times higher than the display resolution. For example, the temperature signal of the instrument is displayed as 1 °C, but the internal PID is still calculated and controlled according to the resolution of 0.1 °C, which can achieve much higher control precision than the display resolution.

In previous versions of the FT series, only the temperature signal was in fine control mode, when the new version is linear input, as long as the displayed value range is less than 3000 words (most applications in industrial applications do not exceed 3000 words), using default fine mode control to obtain higher control precision and more stable output, and when it is necessary to display a value range greater than 3000, SCo.H=1 can be set.

10.12 Communication function

If the COMM port of the meter is configured with an S type RS485 communication interface module. It can realize multi-machine connection with the computer, and can realize various operations and functions of the instrument through the computer. For computers without RS485 interface, an RS232C/RS485 converter or USB/RS485 converter can be added. Every communication port of a computer can connect up to 60 AiFUZZY-800 instruments, or 80 AiFUZZY-800 instruments if a repeater is installed. A computer with 2 communication ports can connect up to 160 instruments. Please note that every instrument connecting to the same communication line should be set to a unique communication address. If the number of instrument are enough, 2 or more computers can be used and a local network can be set up.

The instrument adopts the international MODBUS-RTU communication protocol and the Independence open FTBUS communication protocol. There are a variety of configuration software to support AiFUZZY-800 instrument communication.

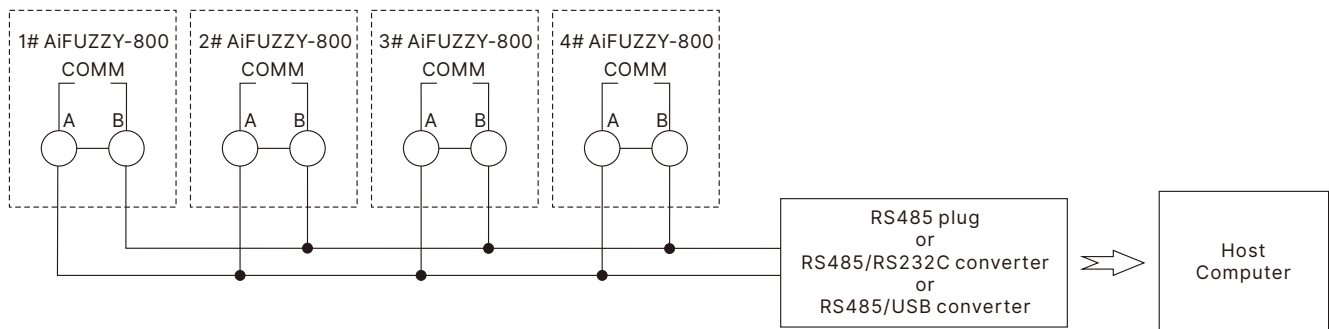

11. Partial application wiring methods

11.1 The wiring method of the input signal

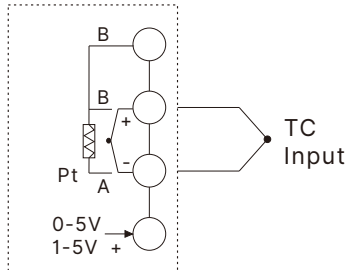
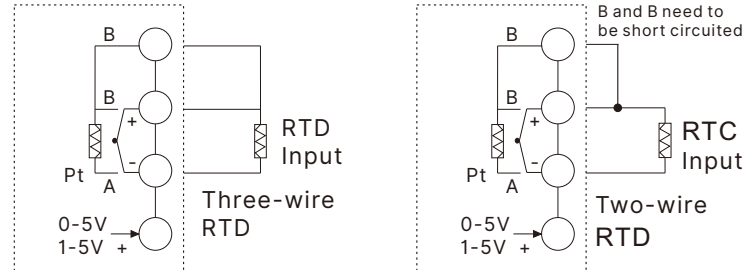
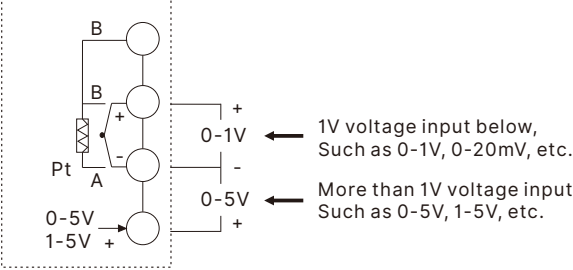
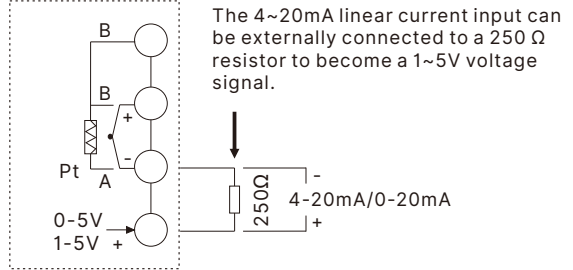
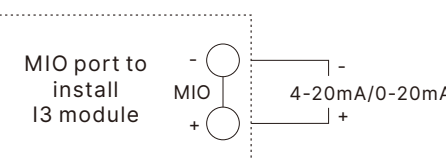
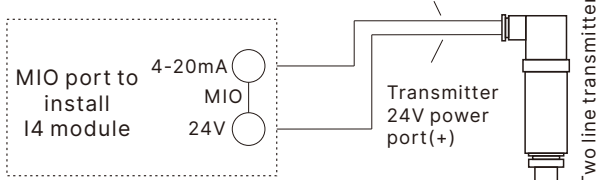
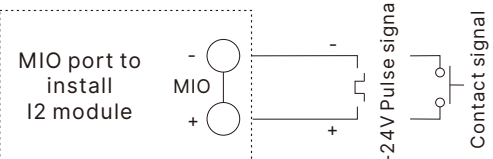
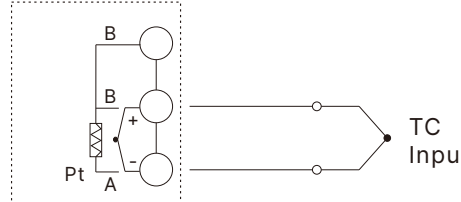
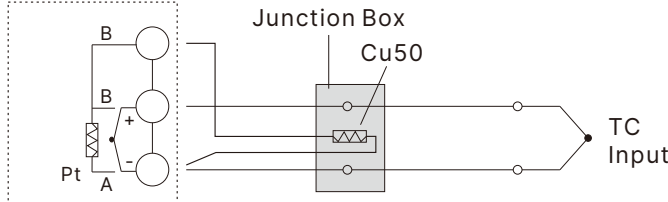
<p>● Thermocouple Input</p> 	<p>● RTDs Input</p> 
<p>● Analog linear voltage input</p>  <p>0-1V ← 1V voltage input below, Such as 0-1V, 0-20mV, etc.</p> <p>0-5V ← More than 1V voltage input Such as 0-5V, 1-5V, etc.</p>	<p>● Analog linear current input</p>  <p>The 4~20mA linear current input can be externally connected to a 250 Ω resistor to become a 1~5V voltage signal.</p>
<p>● MIO port input linear current</p>  <p>MIO port to install I3 module</p>	 <p>MIO port to install I4 module</p> <p>Transmitter 4-20mA output port</p> <p>Transmitter 24V power port(+)</p> <p>Two line transmitter</p>
<p>● MIO port event input</p>  <p>MIO port to install I2 module</p> <p>3-24V Pulse signal</p> <p>Contact signal</p>	<p>If the I2 module is installed on the MIO port, a switch can be connected externally to perform the control function. When the parameter Et=ruSt is set, press the button to perform the run operation, when press the button for 2 seconds or more to execute the stop operation. For the AiFUZZY-819 type meter (or AiFUZZY-879 type instrument parameter PrSn=0) and the parameter EVt=SP1.2, it can be used to switch two different given points SP1/SP2.</p>
<p>● Choosing thermocouple cold junction compensation mode based on wire connection</p> <div style="display: flex; justify-content: space-around;"> <div style="width: 45%;">  <p>(1) Internal automatic compensation mode (Compensating wire shall be directly connected to the connection terminals)</p> </div> <div style="width: 45%;">  <p>(2) Externally connected to copper resistor automatic compensation mode (Thermocouple cold end terminal box had better keep away from heat sources)</p> </div> </div> <p>When using thermocouple as the input, cold junction should be applied for temperature compensation based on the thermocouple temperature measuring principles. All instrument can automatically compensate cold junction referencing the temperature around the wiring terminals. Due to measuring components' errors, instrument's inherent heating and other heat sources nearby, the deviation of automatic compensation modes is comparatively large, for which the worst may exceed 2°C. So if higher accuracy is</p>	

required, an external junction box can be used. Put Cu50 copper resistor (to be purchased separately) and thermocouple cold junction together, and keep away from the heat sources, thus the measuring inconformity caused by compensation may be less than 0.3°C. Because the inherent errors of Cu50 copper resistor may cause certain errors at room temperature, it can be modified with "Sc" parameter. Change the externally connected copper resistor into precision fixed resistance, which may achieve constant temperature bath compensation. For instance, connect it to constant 60Ω resistor, check the reference table of Cu50 and find the compensation temperature of 46.6°C. At this moment, put the thermocouple cold junction into the constant temperature bath for accurate compensation at the temperature of 46.6°C. its compensation accuracy will be better than that of copper resistor. If the externally connected resistance is changed into short circuit, ice-point compensation may be achieved. At this moment, it is required to place the thermocouple cold junction (the joints of the thermocouple or compensation wires and conventional wires) into the ice-water mixture (0°C), its compensation accuracy may reach above 0.1°C.

11.2 Main control output wiring method

●Relay output (OUT port installs R module)

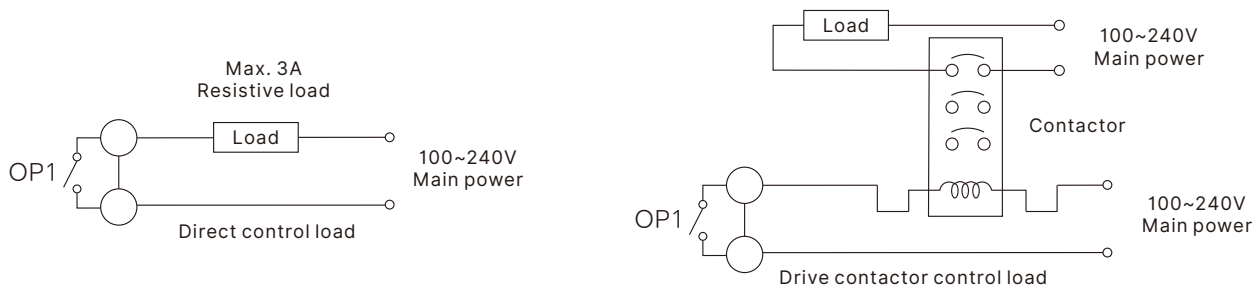

●Thyristor No contact switch output (built-in SSR output)(OUT port installs T module)

Tare new types of no contact switch module which apply the advanced technology of "burn proof" and zero crossing conduction. It can replace the relay contact switch. Compared to the relay contact output module, T have longer life and lower interference. They can be largely lower the interference spark of the equipment, and greatly improve the stability and reliability of the system. It can directly control the resistive load below 1A/240V (for example, it can directly control the maximum 250W heating tube), and above 1A can control the high current load by driving the AC contactor. The drive element of the contactless switch is a thyristor, so it is only suitable for controlling AC power of 100~240VAC specifications, but not for controlling DC power.

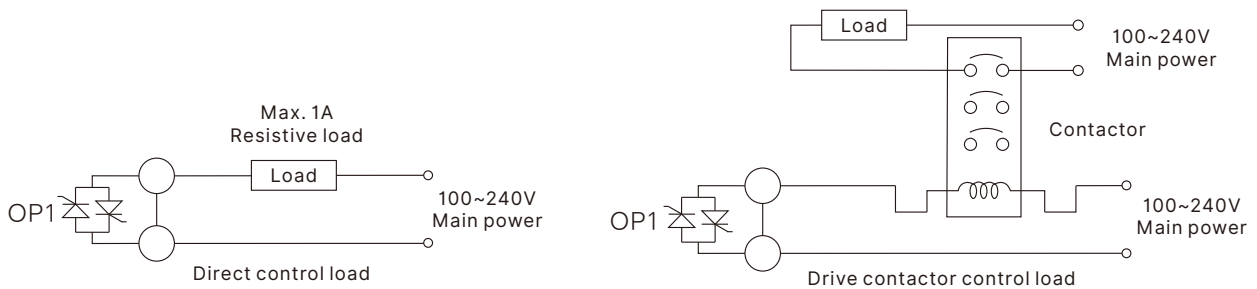

●12V SSR drive voltage output(OUT port installed Q module)

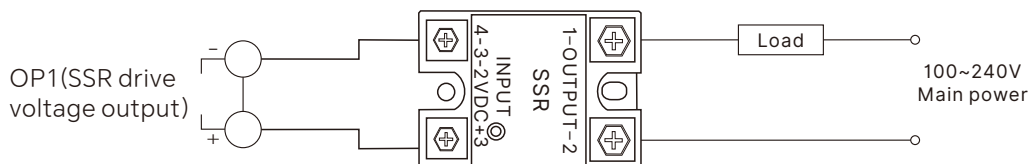

● Thyristor trigger output Wiring diagram

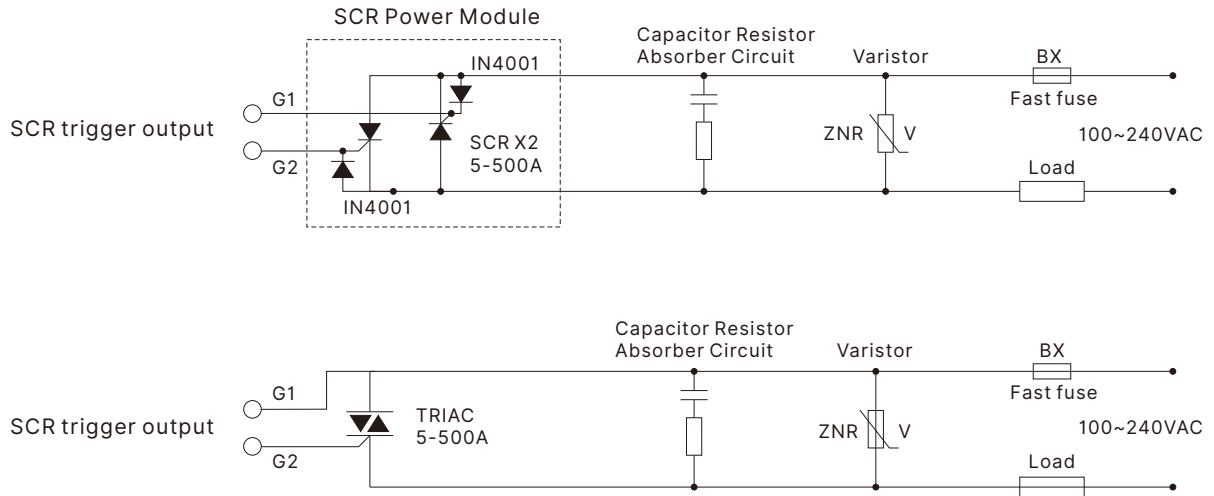

Note 1: According to the voltage and current of load, choose suitable varistor to protect the SCR. Capacitor resistor absorber is needed for inductance load or phase-shift trigger output.

Note 2: SCR power module is recommended. A power module includes two SCRs, is similar to the above dashed square.

Note 3: Phase-shift trigger module K5 only supports 200~240VAC power, and K6 supports 340~415VAC.

● Linear current and voltage output (OUT port installed X, X5, X8 modules)

Can trigger: SCR power regulator, thyristor phase shift trigger module, PLC, inverter, transmitter, valve actuator, etc.

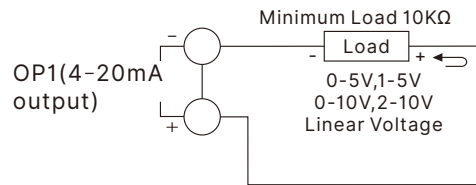
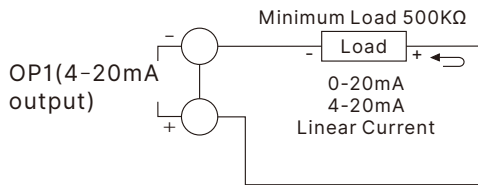

The following figure uses the 4-20mA output to trigger the SCR to achieve power regulation output:

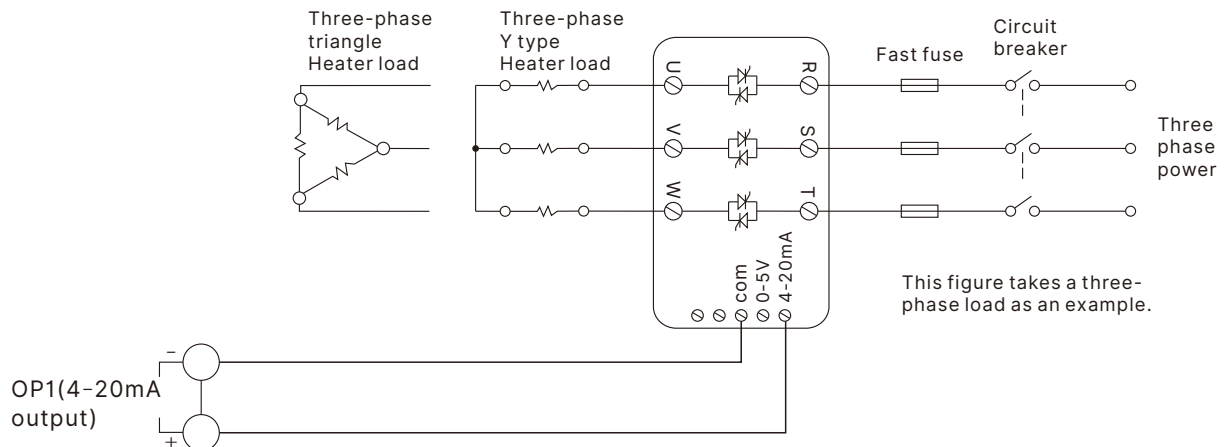

This figure takes a three-phase load as an example.

■ 12. Input fault indication

When the display window PV alternately displays the “orAL” character, it indicates that the input of the measurement signal is abnormal or out of range; please check whether the Int parameter setting is consistent with the input sensor signal type. If it is determined to be consistent, please check if there is any problem with the sensor or wiring.

■ 13. Further explanation of AiFUZZY-879 program control

13. Further explanation for the operation of AiFUZZY-879 series instrument

AiFUZZY-879 program type temperature controller is used in the application where the setpoint should be changed automatically with the time. It provides 80 segments program control which can be set in any slope and the function of jump, run, hold and stop can also be set in the program. Measurement startup function, preparation function and power-cut/power-resume event handling modes also provided.

13.1 Function and Concept

StEP:

The No. of the program Step can be defined from 1 to 80, and the current Step is the program Step being executing.

StEP time:

The total time set for the program segment to run, in minutes or hours, with valid values ranging from 1 to 999.9.

Running time:

The Time of current Step has run. As the running time reaches the Step time, the program will jump to the next Step automatically.

Jump:

The program can jump to any other steps in the range of 1 to 80 automatically as you programmed in the program Step, and realize cycle control.

Run/Hold:

When program is in the running status, timer works, and set point value changes according to the preset curve. When program is in the holding status, timer stops, and set point remains to make temperature hold also. The holding operation can be programmed into the program step.

Stop:

When the stop operation is activated, the program will stop, running time will be clear, event output switch will reset and the output control will stop output. If run operation is activated when instrument is in the stop status, the program will start-up and run again from the set step no. The stop function can be programmed into the program Step. The stop operation can also be performed manually at any time. (After stop operation is done, the step no. will be set to initial segment, but user can modify it again). If the program ran the last step of "PrSn", program will stop automatically.

Power cut/resume event handling:

There are 5 events handling method selectable for power resume after power cut off. Please refer to parameter Pont .

PV startup and PV preparation function (rdy function) :

At the beginning of starting a program, resuming a program after power cut or continuing to run a program after it is just modified, the PV (process value) are often quite different from the set point. PV startup function and PV preparation function can make PV and set point consistent, and avoid unexpected result. When PV startup function enabled, the instrument will adjust the running time automatically to make the expected set point is the same as the current PV.

For example, the program is set that the temperature will be raised from 25°C to 625°C in 600 minutes. But the current PV is 100°C, then the instrument will automatically to run this program start from 75 minutes, that mean changed the temperature raised from 100°C to 625°C in 525 minutes (600-75) min.

At the above situation(PV=100, SV=25, first step SV), when PV preparation function is enable, the alarm function will be blocked at that time, and PV will be adjusted to approach SV until the deviation alarm condition is released (PV is between SV-LdAL and SV+HdAL). After deviation alarm was off, the controller starts to run the program again. Preparation function (rdy Function) is helpful to keep the integrity of the program, but it will prolong the program time because the start of the program is

postponed. PV startup function is prior to PV preparation function. If both function are enabled, the system apply PV startup first, if PV startup function works, PV preparation function will not be activated.

Curve fitting:

Curve fitting is adopted as a kind of control technology for AiFUZZY-879 series instrument. As controlled process often has lag time in system response, by the way of curve fitting the instrument will smooth the turning point of the linear heating-up, cooling-down and constant temperature curves automatically. The degree of the smooth is relevant with the system's lag time t ($t=d+CP$); the longer of the lag time, the curve will more smooth. On the opposite the smooth function will be weaker. Generally the shorter of the process lag time (such as temperature inertia), the better of the program control on effect. By the way of the curve fitting to deal with the program curves, will avoid overshoot. Note: The characteristic of the curve fitting will force the program control to generate fixed negative deviation during the linear heating-up and fixed positive deviation during the linear cooling-down, the deviation is direct proportional to the lag time and the speed of heating-up (cooling-down). This phenomenon is normal.

13.2 Programming and operation (For AiFUZZY-879 only)

13.2.1 Ramp Mode (PSYS : B=0)

Programming of instrument has uniform format of temperature-time-temperature, which means temperature "A"(SP1), passed Time "A"(t01), then reached Temperature "B"(SP2). The unit of temperature set is °C and the unit of time set is minute. The following example includes 5 steps, which is linear temperature heating up, constant temperature, linear temperature cooling down, jump cycling, ready, Hold.

For example:

StEP1: SP1= 100, t-1=-0.1; adopts No.1 PID parameters to control;

StEP2: SP2=100, t-2=30.0 Start linear temperature heating up from 100°C, and the time needed 30 minutes to reach SP2(400 degree).

StEP3: SP3=400, t-3=60.0 Temperature raised to 400°C, slope of raising curve is 10°C/minute, The program take 60 minutes to raise temperature to SP3 (400 degree). It means keep the same temperature in 60 minutes.

StEP4: SP4=400, t-4=120.0 This is the step for temperature cooling down, slope of cooling curve is 2°C/minute, and the time needed is 120 minutes to reach SP4 (160 degree).

StEP5: SP5=160, t-5=0.0 When temperature reached 160°C, the program get in Hold state. If need go to next step, it needed operator to executed the "run" for next step.

StEP6: SP6=160, t-6=-1.0 Jump to StEP1 to start from beginning.

In this example, it is assumed that the deviation high alarm is set to 5°C. Because the temperature of StEP5 is 160°C, and the temperature of StEP1 is 100°C, when program jumps from StEP5 to StEP1, the program will change to preparation state at first (if preparation mode "rdy" was enabled), i.e., Control the temperature until the deviation between setpoint and PV is less than deviation high alarm value. After temperature is controlled to 105°C, the program will be started from StEP1, and run the above steps again. The temperature control drawing was shown below.

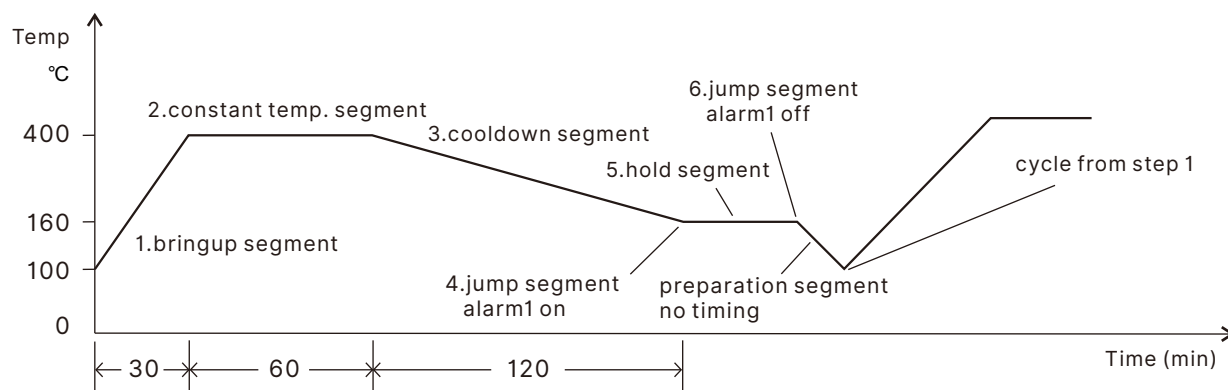

The advantage of using the temperature-time programming method is that the slope of the temperature rise and temperature drop is set to a very wide range. The heating and constant temperature sections have a uniform setting format for easy learning. The setting curve is more flexible, and it can be set to continuously set the temperature rising section (for example, using a warming section with different slopes to approximate the function temperature), or a continuous constant temperature section.

13.2.2 Platform Mode(PSYS : B=1)

Suitable for the process which does not need to establish the temperature slope, can simplify the programming and more effective. Each step also can set parameter "rAte" to define temperature raise slope, if "rAte=0" raising speed will set to maximum. Because cannot know the actual time which spend on temperature raising, user can enable "rdy" function to ensure the correct soak time.

13.2.3 Set the given value and time of the program

Each program includes a given value and time, the given value indicates the temperature value to be controlled, time in besides regard as running time, there are special control functions, when t is positive the value represents the running time, when t is negative value represents a jump + command, The meaning is as follows:

The scope of t: -122.0~3200

t-XX=0.1 ~ 3200 represents the run time value

t-XX=0.0 ~ -0.1 ~ -122.0 represents a jump + command

t's command:

0.0, represents that the controller enters the hold running state (HoLd) in this stage, and the program is suspended here and stops the timing.

-121.0, the program executes the StOP operation and enters a stop state.

-XXX.1, represents that first group of PID parameters are specified.

-XXX.2, represents that second group of PID parameters are specified.

-XXX.3, represents that third group of PID parameters are specified.

-XXX.4, represents the AL1 action.

-XXX.5, represents the release of AL1.

-XXX.6, represents the action of AL1 and AL2.

-XXX.7, represents the release of AL1 and AL2.

-XXX.8, indicating that AL1 outputs a 0.5 second pulse action, and the program continues to execute the next segment. However, if the alarm 1 has been activated, whether it is caused by the event output or not, the pulse action is canceled and the alarm 1 state remains unchanged.

For example, if t-1 = -0.1 is set, the first group of PID parameters will be executed and the PIDn parameter will be set to 1 automatically when running to the first-stage program.

For another example, setting t-7 = -11.2 means that when running reaches the program in the 7th stage, it will jump to the 11th stage to execute and specify the second group of PID parameters, and the PIDn parameter will be set to 2 automatically.

For example: Set t-5 = -1.4, which means that when running to the fifth-stage program, AL1 action and jumps to the first-stage running.

Note: In addition to the implementation of the operation or switch on the power to meet the jump segment can continue to jump to run in the program run to allow up to 2 consecutive jumps, continuous 3 or more jumps the program automatically suspended execution (That is, the instrument automatically inserts a suspend operation for three consecutive jumps), an external running operation is required to release the suspended state. Note that if the jump segment is itself (for example, t-6 = -6), the pause state will not be able to be released because such a segment is meaningless.

13.2.4 Multi-group PID application case

SP1 = any value, t1 = -0.1, the next paragraph, specify the first group of PID parameters (PIDn parameters automatically 1);

SP2 = 100, t2 = 30.0 at 100°C, the linear temperature was raised to SP3, the temperature rising time was 30 minutes and the temperature rising rate was 10°C/ minute;

SP3 = 400, t3 = 60.0, Reach 400°C and keep warm for 60 minutes;

SP4 = 400, t4 = -0.2, the next paragraph, specify the second group of PID parameters (PIDn parameters automatically 2);

SP5 = 400, t5 = 80, heated to 800°C at 400°C for 80 minutes and heated at a rate of 5°C/ min;

SP6=800 , t6=-0.8 , Reach 800°C, AL1 outputs a 0.5 second pulse action and continues to execute the next segment;

SP6=800 , t6=-0.8 , Reach 800°C, AL1 outputs a 0.5 second pulse action and continues to execute the next segment;

SP7 = 800, t7 = 120.0, In 800°C and keep warm for 120 minutes;

SP8 = 800, t8 = -0.3, continue to the next paragraph, specify the third group of PID parameters (PIDn parameters automatically 3);

SP9 = 800, t9= 60.0, heated to 1220°C at 800°C for 60 minutes and heated at a rate of 7°C/ min;

SP10 = 1220, t10 = 60, Reach 1220°C and keep warm for 60 minutes;

SP11 = 1220, t11 = -121.0, The instrument performs STOP operation, the instrument stops control output, and the program stops running. If it is necessary to re-run the program, press the **✓** key for 2 seconds to make the meter execute RUN and start from the head loop.

13.2.5 Auto-tuning program setting method

For example: auto-tuning the first group PID, auto-tuning target value 400°C.

SP1 = any value, t1 = -0.1, the next paragraph, specify the first group of PID parameter groups (if you specify the second group PID parameter group, set t1 = -0.2, if you specify the third group PID parameter group, then set t1=-0.3);

SP2 = 400, t2 = 100.0 (t2 is any positive number value), and the auto-tuning target value is 400 °C.

SP3 = 400, t3 = -1.0, jump to the first paragraph, so that the program is kept at a constant temperature of 400°C.

After setting the auto-tuning program, set At=on to enable the auto-tuning function.

14. Dimensions and installation instructions(mm)

● G-types panel

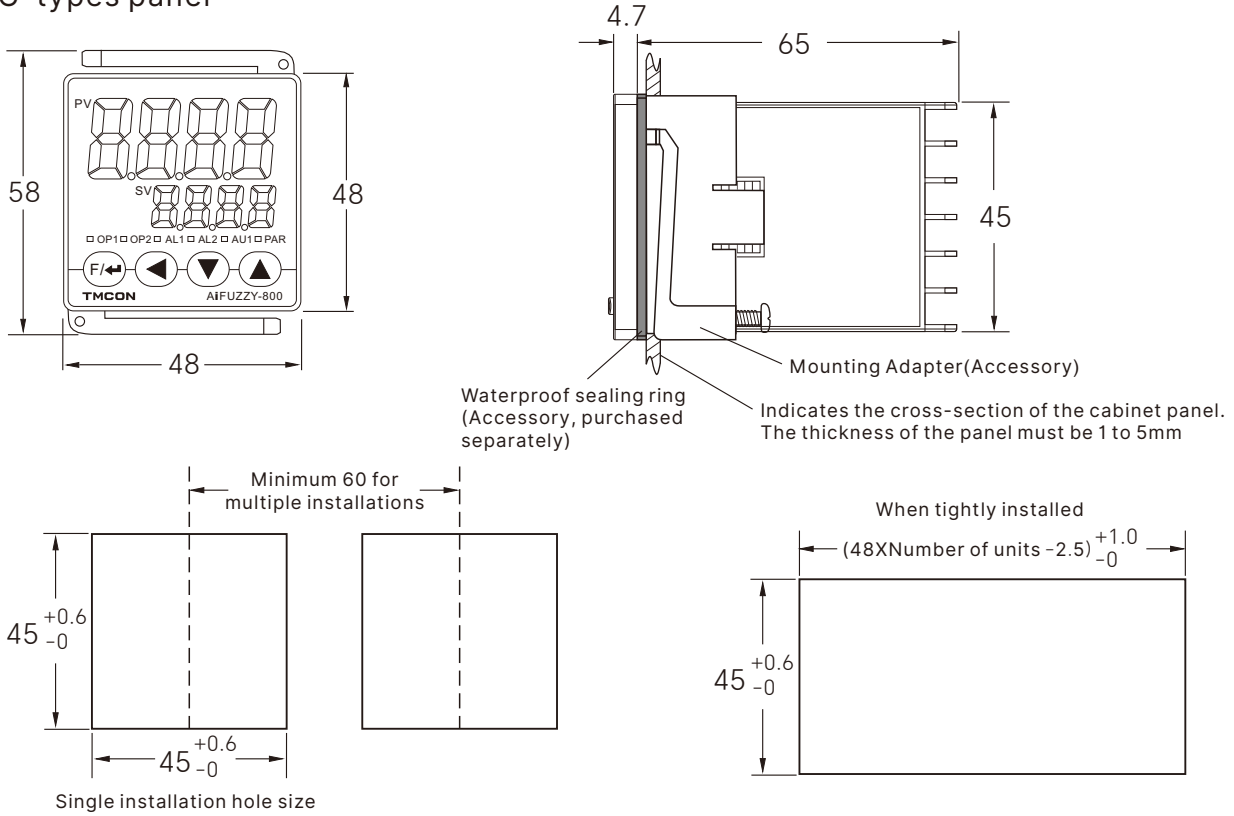

● D-types panel

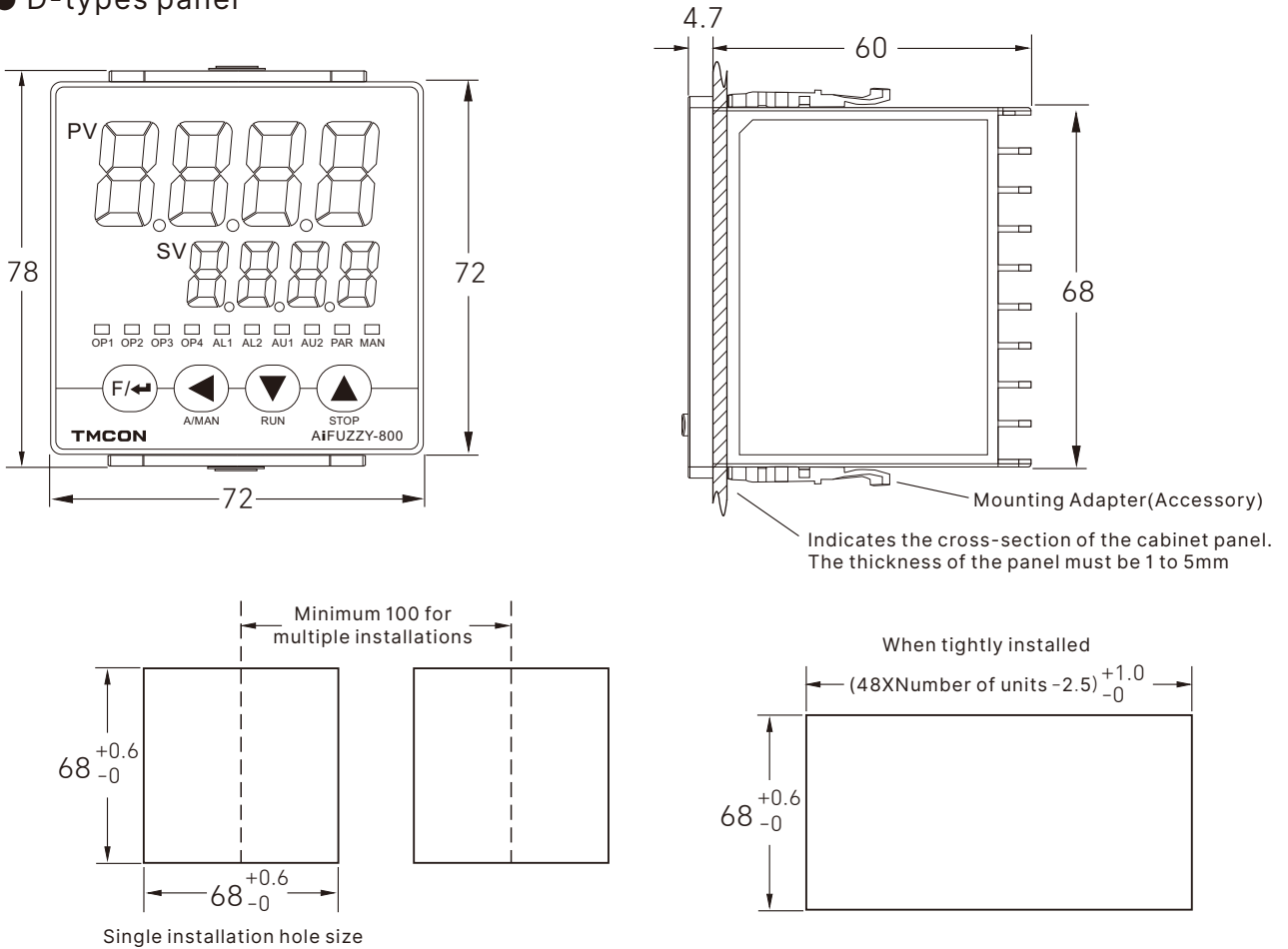

● A-types panel

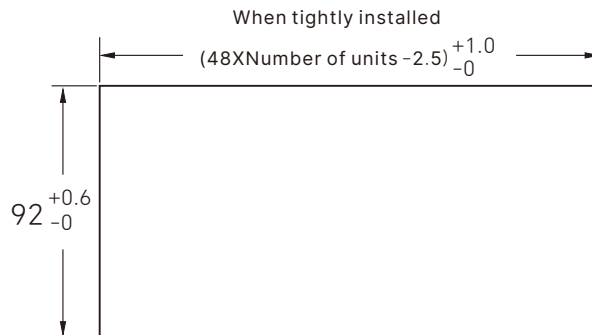
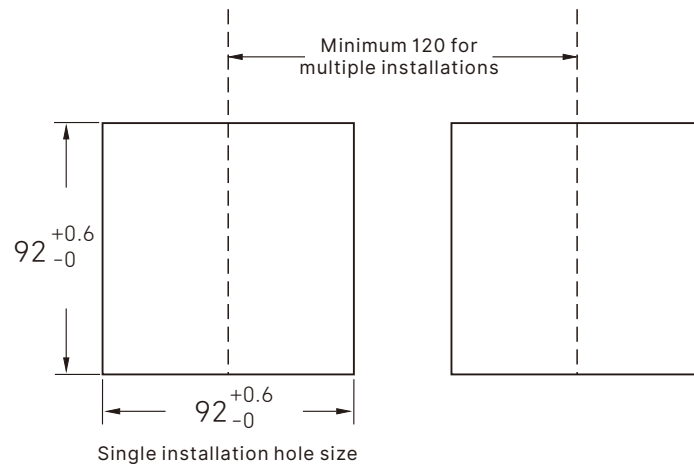
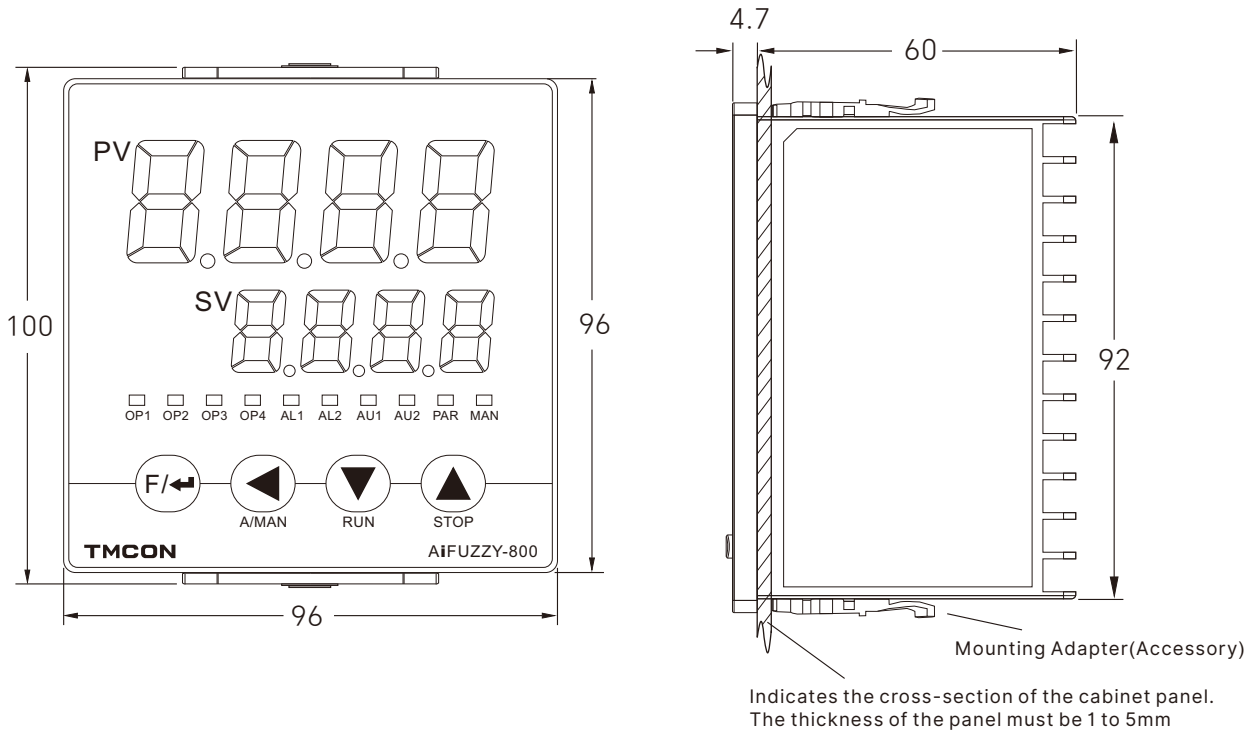

● E-types panel

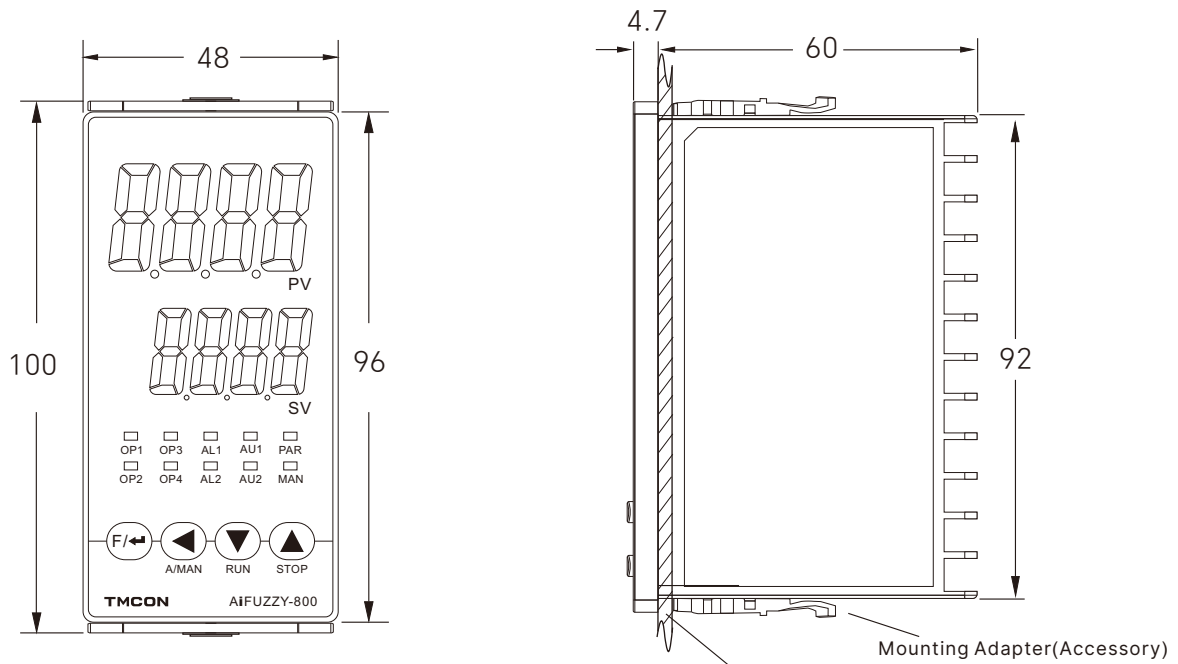

Indicates the cross-section of the cabinet panel.
The thickness of the panel must be 1 to 5mm

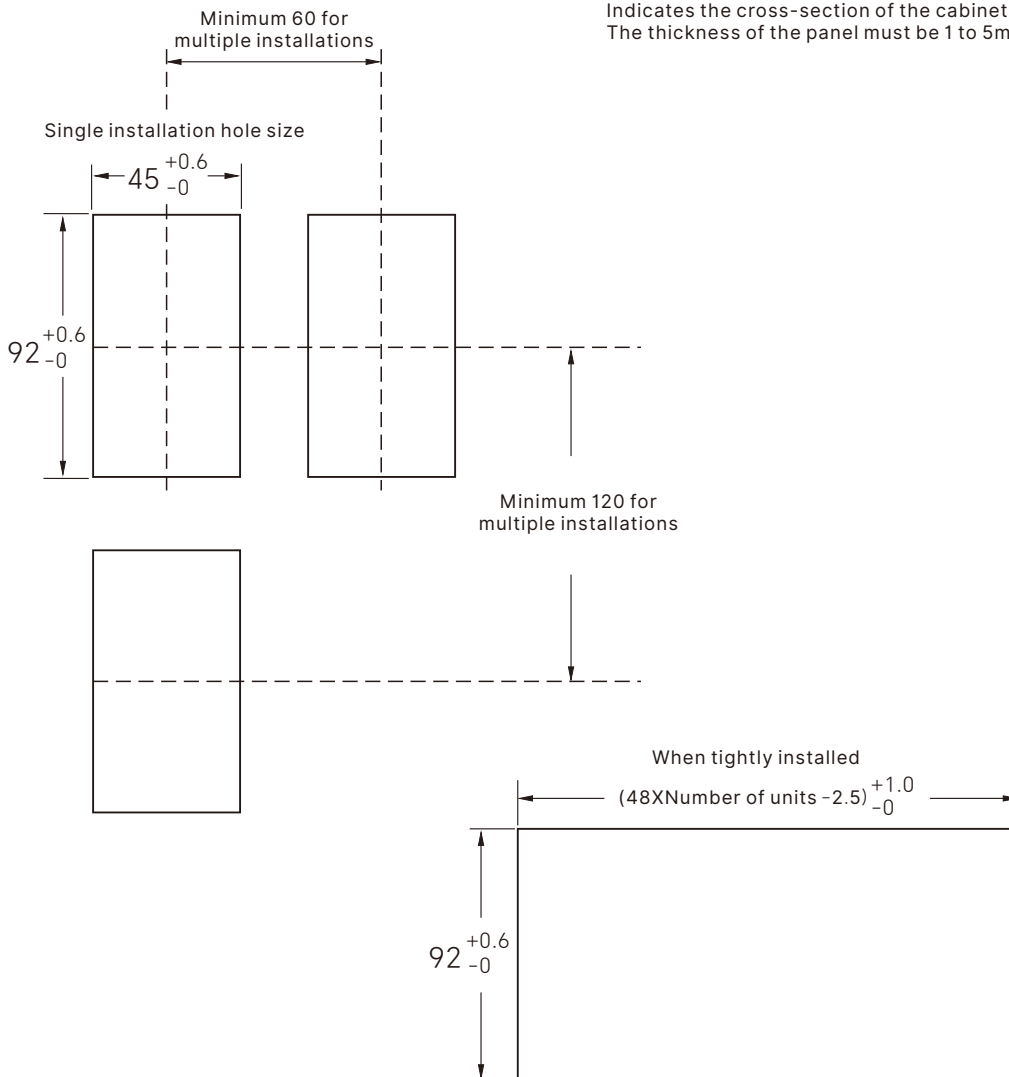

● F-types panel

